

12-18" FULL FLOOR TRANSITION

When installing the GSI aeration transition, it will be necessary to field cut a hole into the bottom sidewall ring. Refer to diagram A for proper dimensions of cutout. Take note of

the diagram showing the 1" dimension from bottom of entrance collar side bracket to concrete. This dimension is important for proper fit of transition.

Field drill bolt holes into sidewall sheet for entrance collar sides and sizing angle. Completely seal all possible spots for water and air leakage with the provided tube caulking.

DIAGRAM A: AS VIEWED FROM INSIDE BIN

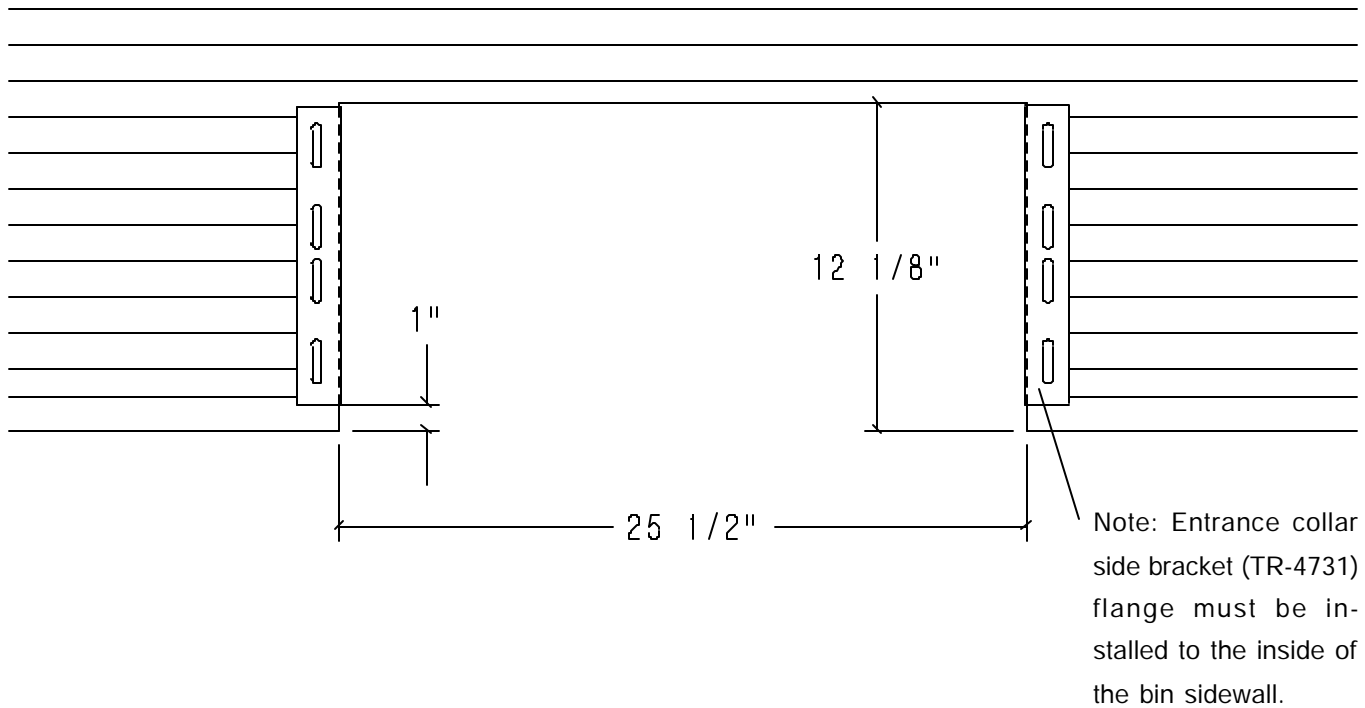

12-18" FULL FLOOR TRANSITION

TRANSITION ASSEMBLY TR-4734

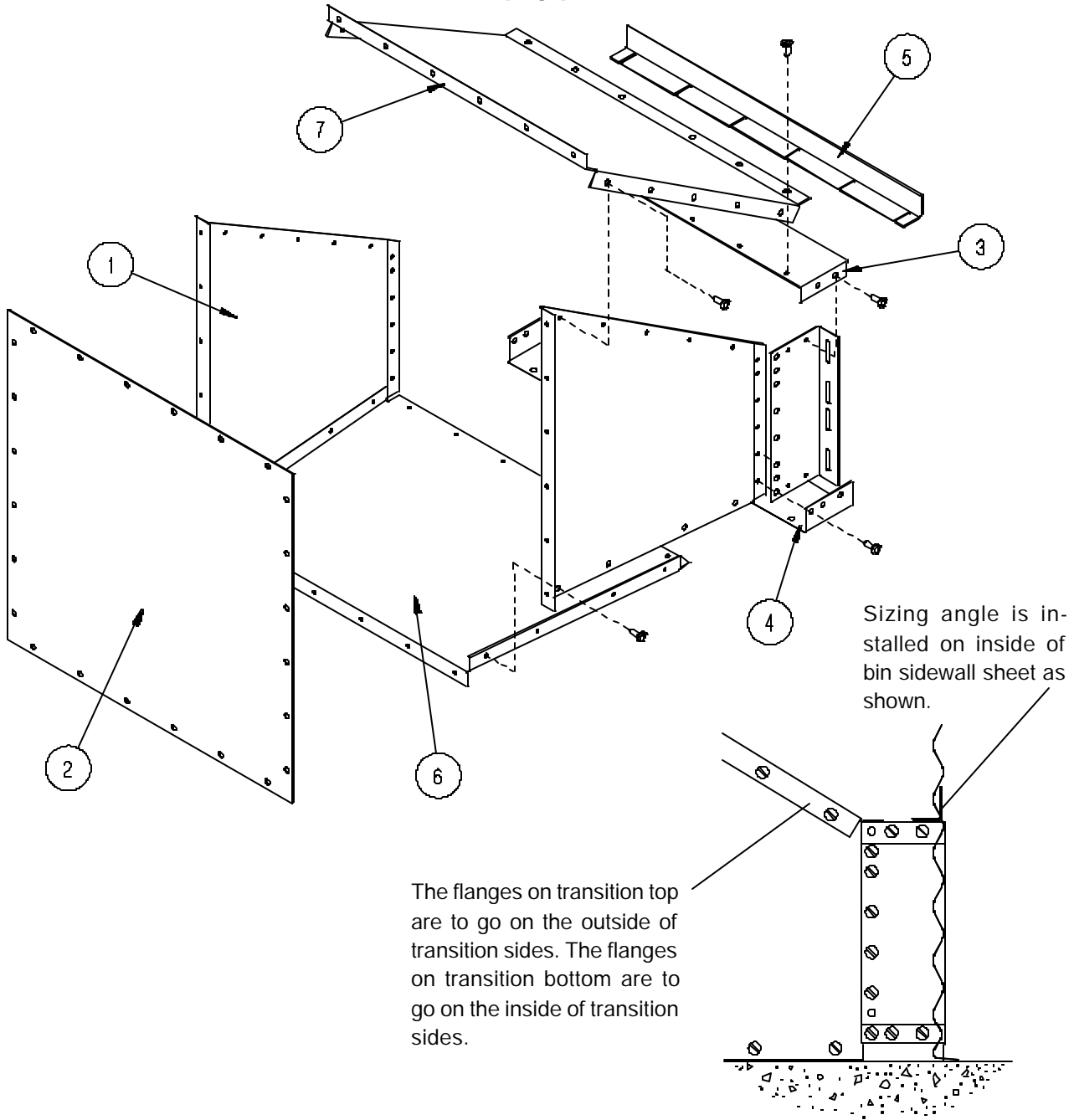

Key	Part Number	Description
1	TR-4724-1	Transition side
1	TR-4724-2	Transition side
2	TR-4767	Transition faceplate
3	TR-4726	Top entrance collar piece
4	TR-4727	Bottom entrance collar
5	TR-4728	Sizing angle
6	TR-4729	Transition bottom
7	TR-4730	Transition top
8	TR-4731	Entrance collar side bracket