

LANTH21387

Installation Instructions

Telescoping and Folding Combine Header Trailer Hitch for JD® “X9” Series Combines

LANKOTA®

**270 West Park Avenue
Huron, SD 57350
866-526-5682**









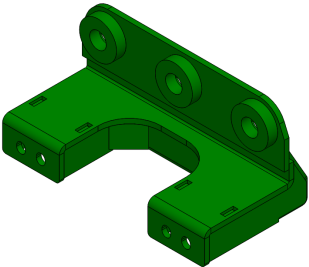
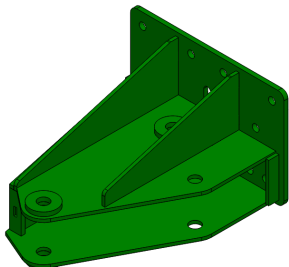
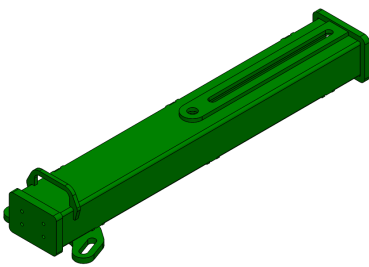
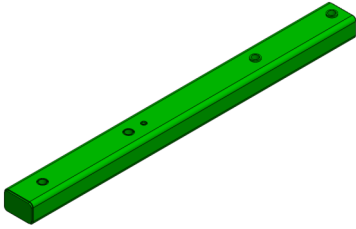
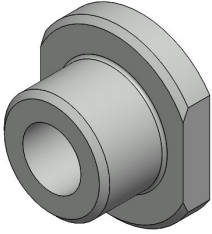

Numerical Parts List

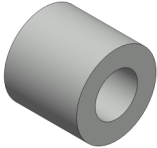
Part Numbers	Description	Qty
LAN2138701A	Hitch Mount Backing Plate	1
LAN2138702	Hitch Mount	1
LAN2138703	Swivel Tube Weldment - Outer	1
LAN2138704	Swivel Tube Weldment - Inner	1
LANTH21387BH	Box of Hardware	1
LAN2138705A	Axle Puck - Threaded	2
LAN2138707	Hitch Mount Shim	10
LAN2138710	Axle Puck - Unthreaded	2
LAN2138711	Tube Slide Stop Bushing	2
LANFRCRF	M20 x 220mm, Gr. 10.9 Hex Bolt	3
LANFHGCF9	M20 Extra Thick Flat Washer	3
LAN19M7824	M16 x 60mm, Gr. 10.9 Flange Bolt	4
LANFHMKN2	M16 Flange Center Lock Nut	4
LANHH80200	1-1/4" Lockease Hitch Pin	2
LANHW8223	1-1/4" x 7-3/4" Pivot Pin	1
LANF0I8B	1/4" x 2.5" Slotted Spring Pin	2
LANF91090A122	3/8" Fender Washer	2
LANFB305	3/8" x 1-1/4", Gr. 5 Hex Bolt	2
LANFH5CJJ	3/8" Center Lock Nut	2
LANFB526	1/2" x 6-1/2", Gr. 5 Hex Bolt	1
LAN1137030	1/2" Nylon Lock Nut	1
LANFOEM6	1-3/8" SAE Flat Washer	1

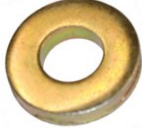
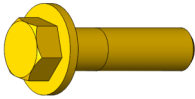
Optional Parts List

Part Numbers	Description	Qty
LANTH1451W	Bolt-on Clevis Hitch Weldment	1
LANF2II7	1/2" x 2" Gr 8 Hex Bolt	4
REDWL55	1/2" Lock Washer	4
LANFWS55	1/2" SAE Washer	4
or		
LAN10040	15 Ton Bolt-on Pintle Hitch Kit	1

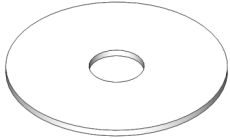
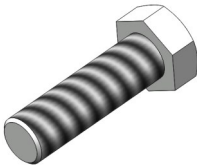
Pictorial Parts List

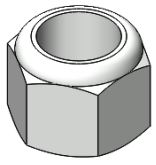
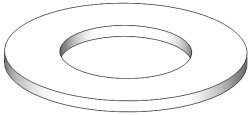
				
LAN2138701A (1)	LAN2138702 (1)	LAN2138703 (1)	LAN2138704 (1)	LAN2138705A (2)
				
LAN2138707 (10)	LAN2138710 (2)	LAN2138711 (2)	LANFRCRF (3)	LANFHGCF9 (3)
				
LAN19M7824 (4)	LANFHMKN2 (4)	LANHH80200 (2)	LANHW8223 (1)	LANF0I8B (2)
				
LANF9109A122 (2)	LANFB305 (2)	LANFH5CJJ (2)	LANFB526 (1)	LAN1137030 (1)
				
LANF0EM6 (1)				

Optional Pictorial Parts List

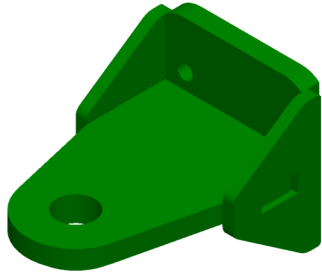

LANTH1451W (1)

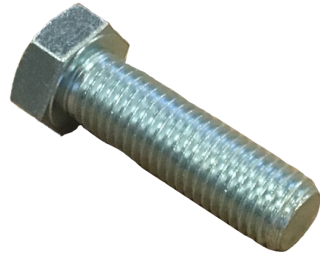

LANF2II7 (4)



REDWL55 (4)

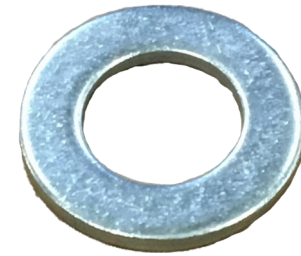

LANFWS55 (4)

(OR)

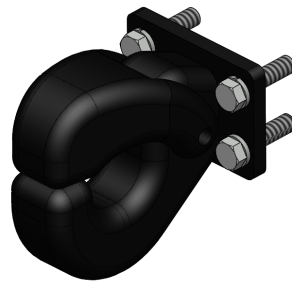

LAN10040 (1)



LANF506 (4)

Preparation

1. Park combine on hard, level surface.
2. Steer the rear wheels to the left and raise the straw spreader to provide more space for installing this hitch.
3. Set the parking brake on the combine.
4. Turn off the combine engine and remove the key.

Kit Installation

Refer to Figures 1 & 2

1. The bolts on the X9 rear axle will be in one of two configurations, however, the Lankota hitch is designed to easily work with either configuration.

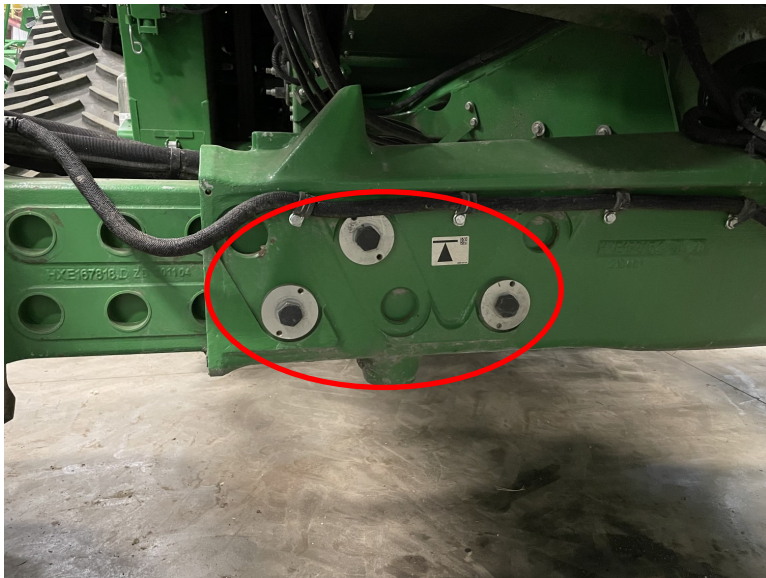

Figure 1

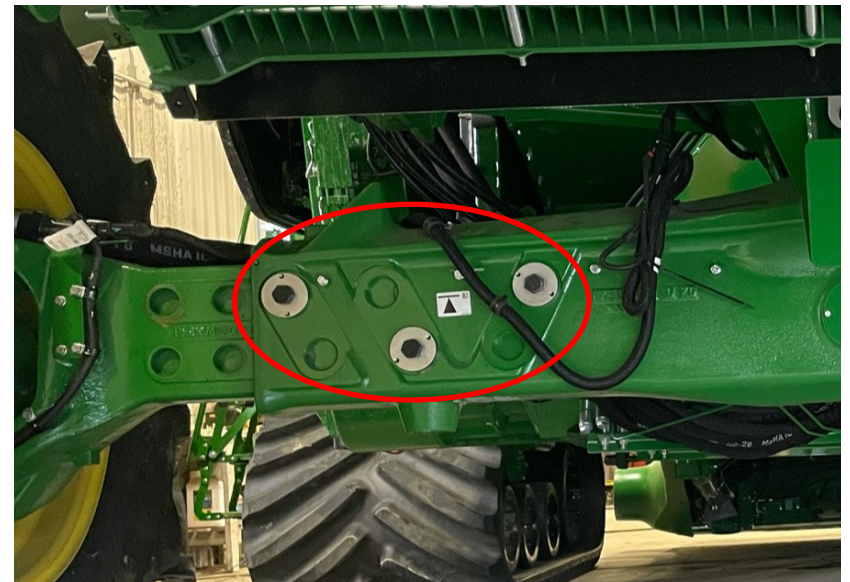

Figure 2

Kit Installation

Refer to Figures 3 & 4

- Remove the three factory axle bolts. The large factory bushings should remain in position. The large threaded factory plate(s) on the front side of the axle, in the bottom row of bolts, will be removed and will NOT be re-used. The top plate(s) will be retained for attaching the Lankota hitch mount.

Figure 3

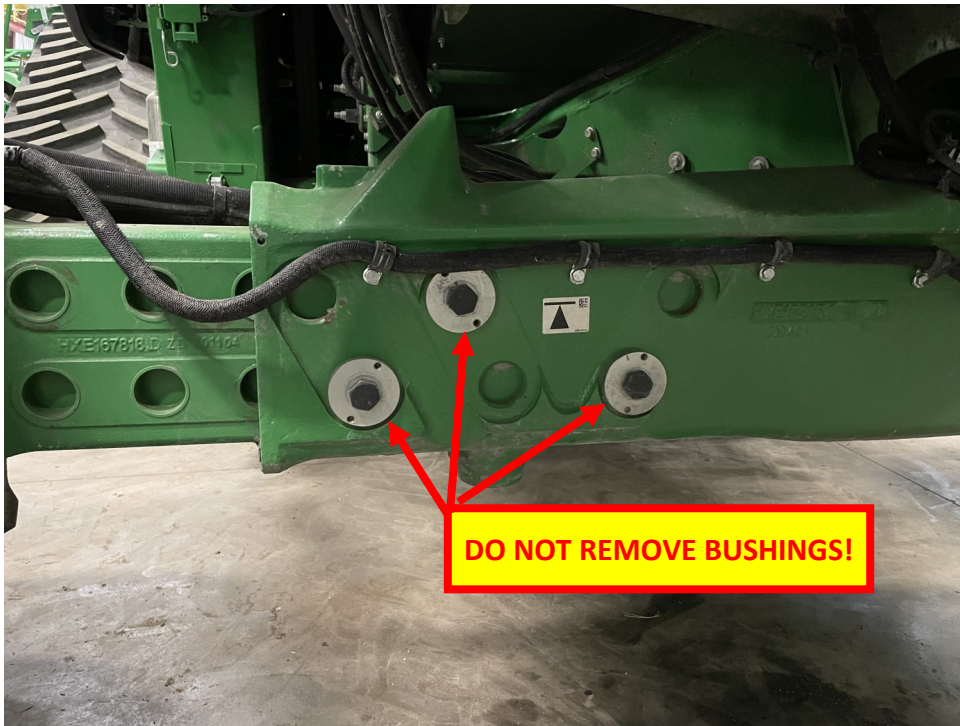
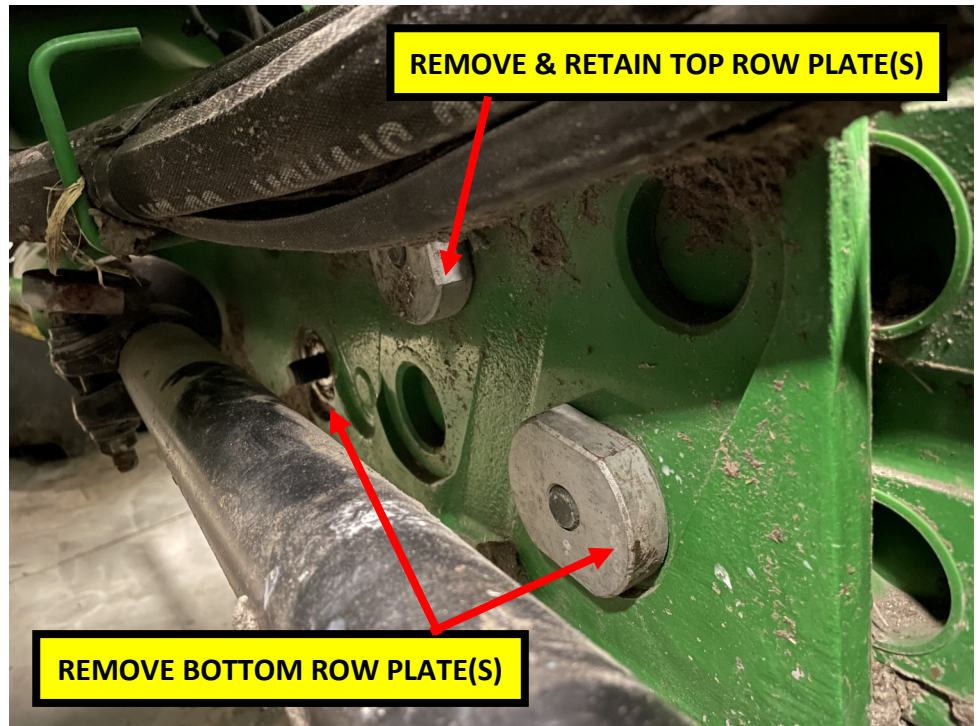

Figure 4



Kit Installation

Refer to Figures 5 through 7

3. Loosen and move out of the way any factory wiring harnesses. Raise the Hitch Mount (LAN2138702) into place and align holes in the mount with the three bushings in the axle frame. The mount will mount over the bushings.

NOTE: Depending on your axle position, there will either be two bolts on the bottom side of the axle and one on the top side (as pictured), or vice versa.

4. Install the top row of M20 x 220mm bolts (LANFRCRF) as shown in Figure 6. Insert the bolts from the rear of the axle frontward using one M20 extra thick flat washer (LANFHGCF9) under each bolt head. The factory threaded puck will act as the nut for the upper bolts on the front side of the axle (Figure 7) Leave these bolts loose at this time.

Figure 5

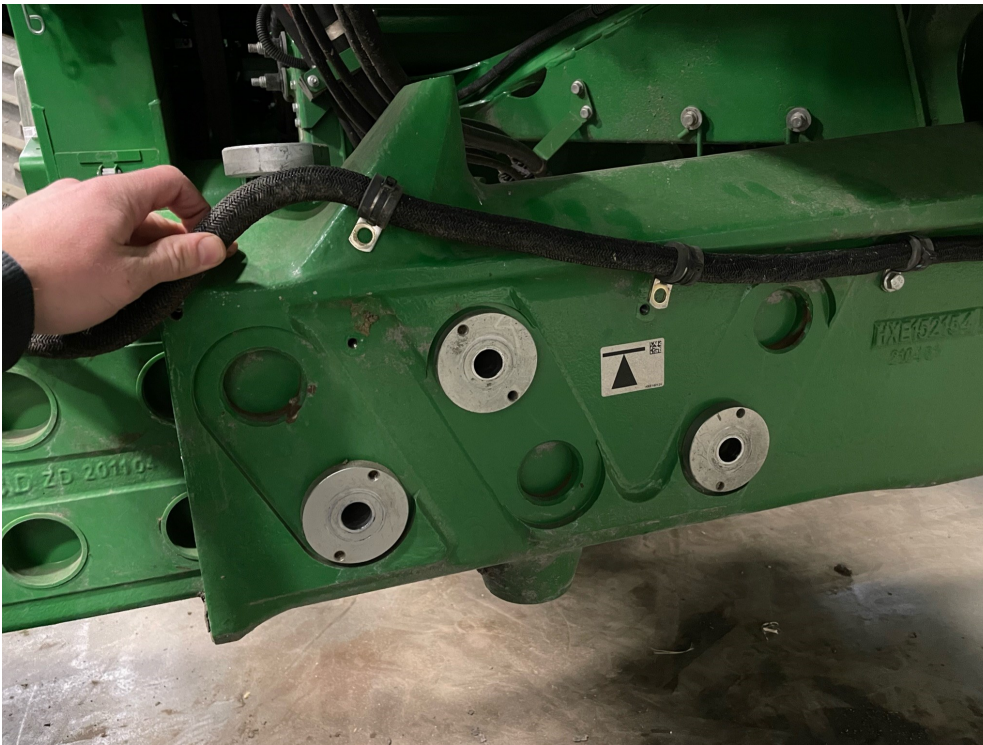

Figure 6



Figure 7



Kit Installation

Refer to Figures 8 through 10

5. The Hitch Mount Backing Plate (LAN2138701A) will need the Unthreaded Axle Puck(s) (LAN2138710) installed in the lower set of axle holes that will not be utilizing the M20 bolts. Use the 3/8" Fender Washer (LANF91090A122), 3/8" x 1-1/4", Gr. 5 Hex Bolt (LANFB305) and 3/8" Center Lock Nut (LANFH5CJJ) to retain these pucks with the head of the bolt toward the axle and the fender washer on the nut side.
6. Install the bottom row of M20 x 220mm bolts (LANFRCRF) with the Threaded Axle Pucks (LAN2138705A) as nuts on the front side of the axle. Insert the bolts from the rear of the axle frontward using one M20 extra thick flat washer (LANFHGCF9) under each bolt head. Tighten the three M20 bolts.

Figure 8



Figure 9



Figure 10



Kit Installation

Refer to Figures 11 & 12

IMPORTANT: Shims (LAN2138707) are provided to take up excess gap between the backing plate (LAN2138701A) and the mount plate (LAN2138702) - Make sure to use just enough shims should to provide a 1/8" to 3/16" gap between the two mounts before the M16 bolts are tightened.

7. With the proper number of shims in place, loosely fasten the backing plate to the mount plate with M16 x 60mm Flange Head Bolts (LAN19M7824) and M16 Flanged Center Lock Nuts (LANFHMKN2). Confirm the gap falls within the range provided. This will ensure the hitch has the proper clamping force on the axle. Tighten the hardware incrementally until the gap is eliminated.

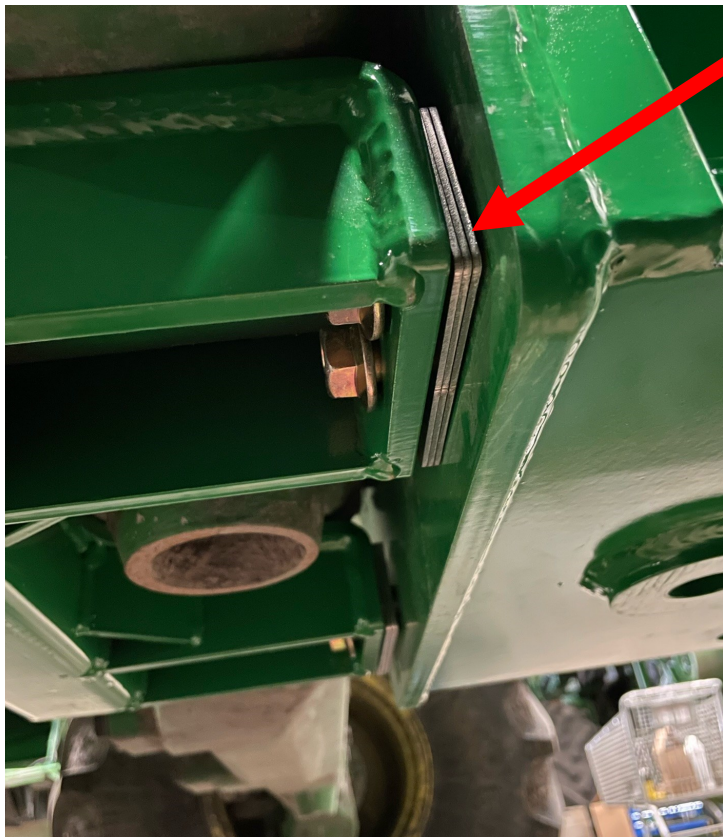

Figure 11



Figure 12

Kit Installation

Refer to Figures 13 & 14

8. With all personnel and tools out of the way, turn on the combine and turn the rear wheels completely to one side. Verify the steering arm clears the Hitch Mount Backing Plate (LAN2138701A) and all newly installed hardware.
9. Turn the combine off and remove the key.

Figure 13



Figure 14



Kit Installation

Refer to Figures 15 through 17

10. Pre-install one slotted spring pin (LANF0I8B) through one end of the 1-1/4" pivot pin (LANHW8223).
11. Install the Inner Swivel Tube Weldment (LAN2138704) into the Hitch Mount (LAN2138702) with a 1-3/8" Flat Washer (LANF0EM6) installed on the bottom side of the tube. The raised lips of the tube bushings should be facing upward. Insert the pivot pin through the hitch mount and inner swivel tube weldment from the top.
12. Install the second slotted spring pin through the other end of the pivot pin to retain it in place.

Figure 15



Figure 16



Figure 17



Kit Installation

Refer to Figures 18 & 19

- Slide the Outer Swivel Tube Weldment (LAN2138703) over the Inner Swivel Tube Weldment (LAN2138704) and secure with the 1-1/4" Lockcase Pin (LANHH80200). The hitch can then be locked in the tow or folded position with a second 1-1/4" Lockcase Pin.

Figure 18



Figure 19



Kit Installation

Refer to Figure 20

14. Assemble the slide stop using the provided Tube Slide Stop Bushings (LAN2138711), 1/2" x 6-1/2" Hex Bolt (LANFB526), and 1/2" Nylon Lock Nut (LAN1137030).

Figure 20

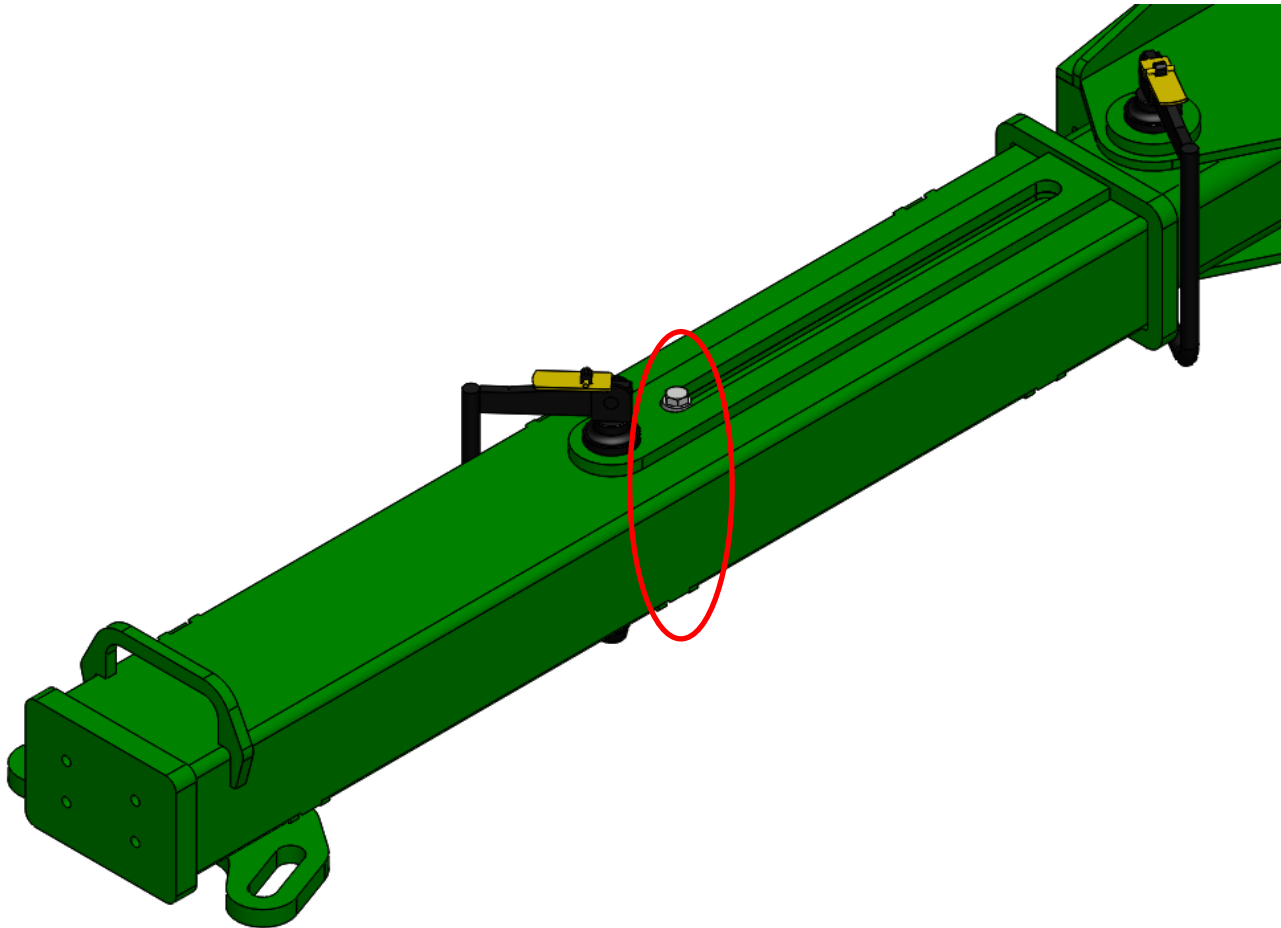

Kit Installation

Note: If the tube weldment does not ship with the appropriate hitch bolted on, follow these steps.

Refer to Figure 21

15. Ensure the threaded holes are clear of any debris by blowing them out with compressed air.

Refer to Figure 22 (For Clevis Hitch)

16. Bolt on the clevis hitch weldment (LANTH1451W) with the provided 1/2" x 2" bolts, lock washers and flat washers.

Refer to Figure 23 (For Pintle Hitch)

17. Bolt on the pintle hitch with the hardware included in the kit and the 1/2" x 1.5" Bolts.

Figure 21



Figure 22

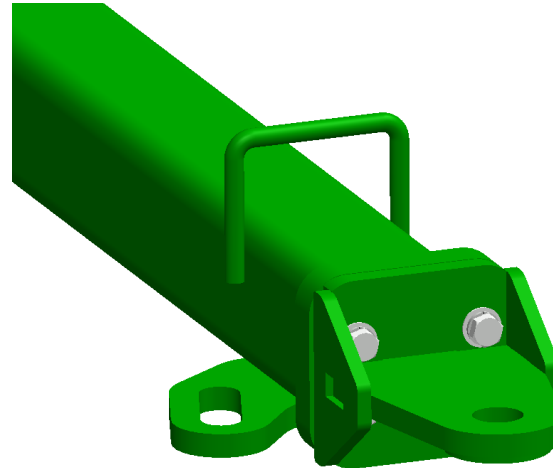
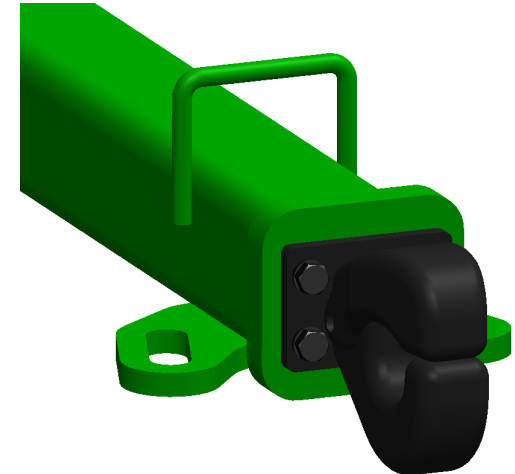

Figure 23



For further technical assistance,

Call Lankota Inc. at:

1-866-526-5682