



INSTALLATION of the JD 600 Series Flex Grain Platform Auger Trough Liner Kit

**IT IS VERY IMPORTANT THAT YOU READ THE ENTIRE
INSTRUCTION SHEET BEFORE STARTING INSTALLATION**

**PLEASE REFER TO THE OPERATORS MANUAL FOR YOUR
SPECIFIC COMBINE FOR PERTINENT SAFETY PRECAUTIONS**

Compare the contents with the enclosed "packing list" to confirm
that you have received the correct parts and associated hardware.

PANEL LAYOUT

THE TERMS "LEFT", "RIGHT", "FRONT", and "REAR " ARE DETERMINED BY
FACING IN THE DIRECTION THE COMBINE WILL TRAVEL WHEN IN USE.

FORWARD



20 FT

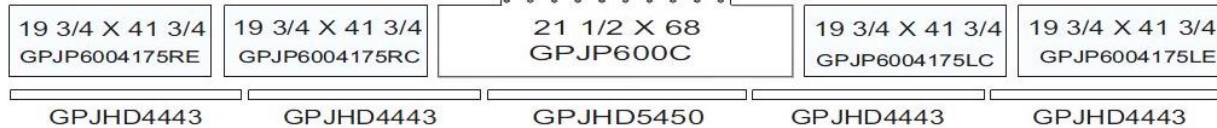

22 FT

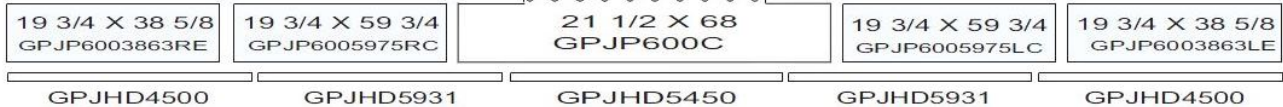

25 FT

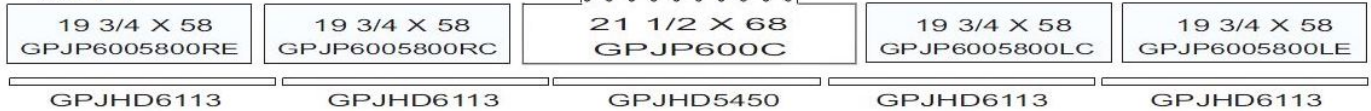

30 FT

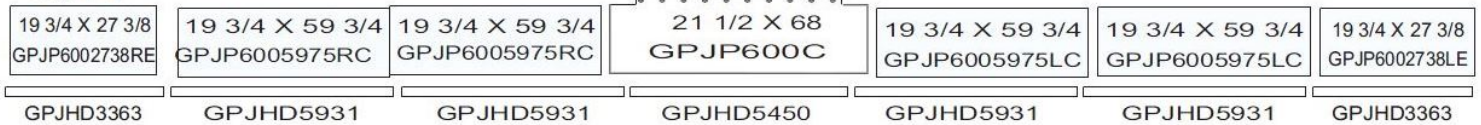

35 FT

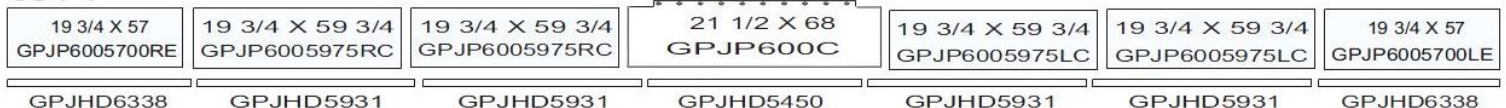

GPJK600_05OCT10

Copyright© 2010 Poly Tech Industries, Inc.

Hydraulic Cylinder Safety Stop

Lower safety stop (A) onto hydraulic cylinder rod.

A—Safety Stop

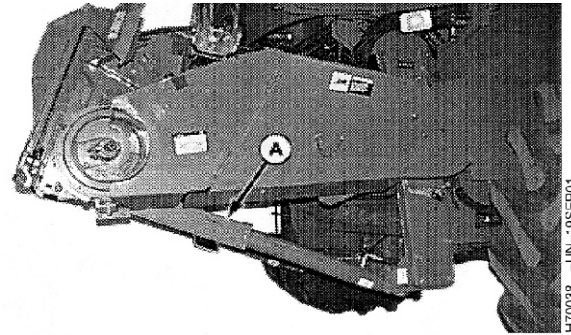

H70038 -JUN-95EP01

Setting Reel Safety Stops



CAUTION: Lower both safety stops (A) when working under or on the reel.

Sound horn, start combine engine and raise reel all the way. Stop combine engine, set parking brake and remove key.

Unhook stop (A) from storage clip, lower stop completely and ensure lock snaps are locked on cylinder rod.

Repeat steps for other side of platform.

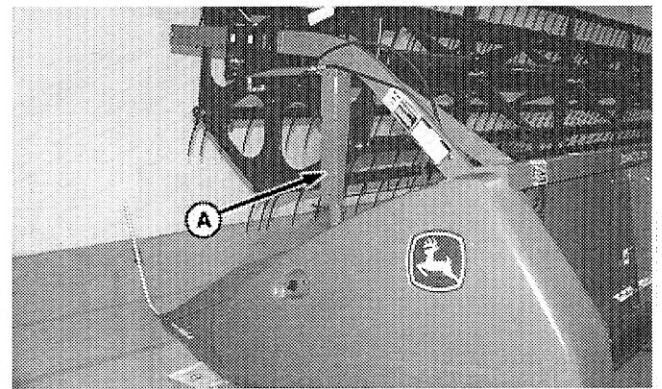

Rigid platform shown

**When using power tools,
basic safety precautions
should always be followed
to reduce the risk of injury
WEAR SAFETY GLASSES
OR GOGGLES**

IMPORTANT

The floor strippers (5/8 x 1 steel angle) are required to secure the rear of the liner.

If your header is not equipped with floor strippers, it will be necessary to acquire them from your dealer before you can successfully install the liner kit.

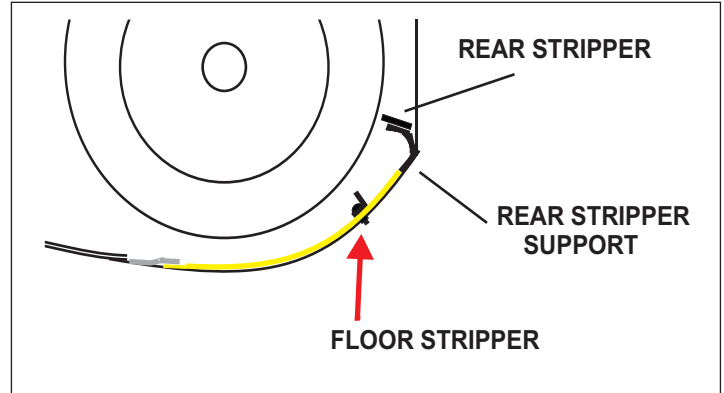

STEP 1 Raise each end of the auger approximately 3/4 inch to allow the floor strippers to be removed thru the front of the header.



STEP 2

Remove both floor strippers.



NOTE: WITH FLOOR STRIPPERS REMOVED, THOROUGHLY CLEAN THE AUGER TROUGH TO REMOVE ALL DIRT AND CROP RESIDUE.

STEP 3 Insert the center panel (GPJP600C) under the auger.
Center the panel in the rear opening.

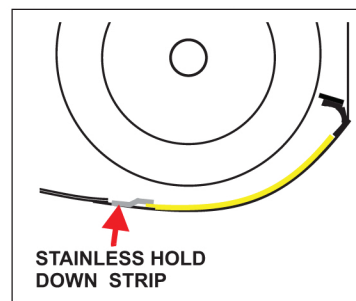

STEP 4 Position the panel and the hold down strip labeled **GPJHD5450** immediately behind the metal frame as illustrated to the right.

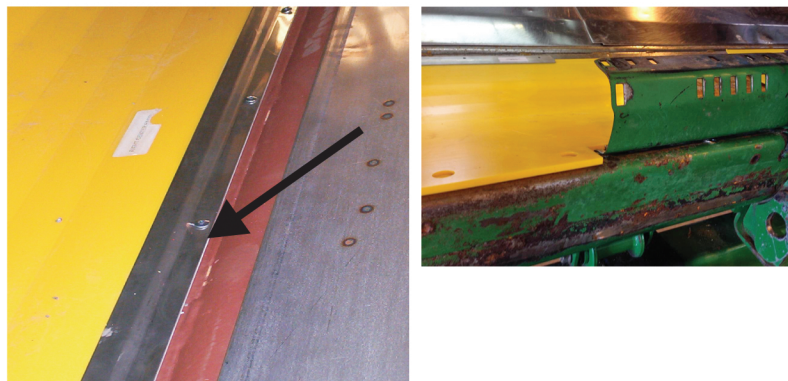

Center the hold down strip between the cut outs as illustrated below.

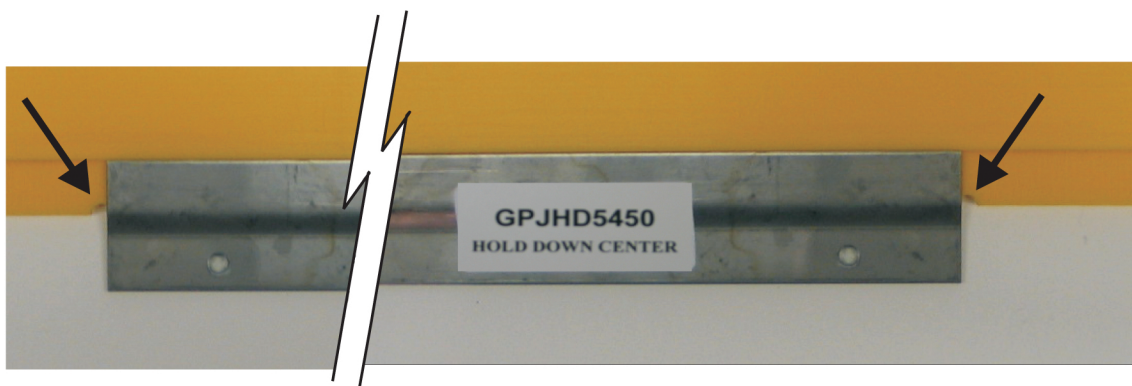

STEP 5 Drilling with the 13/64" drill bit supplied, secure the hold down strip with the 3/16 x 1/4 rivets.
Install a rivet in each hole before drilling the next hole.



STEP 6

With the leading edge of the panel secured, wedge the liner tight against the auger trough floor with the wooden shims supplied.



Working from the center outward, install the left center panels and left end panel using the same procedure as described in Steps 4 and 5.

Position the panels with a 3/16 inch gap at each joint using the gauge block supplied.

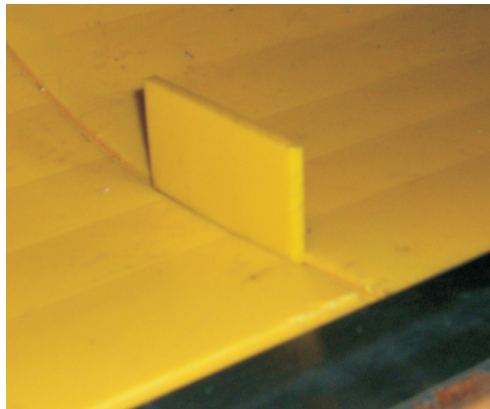

Install the mating hold down strips with no gap at their joints.

Secure the hold down strips as described in Steps 5.

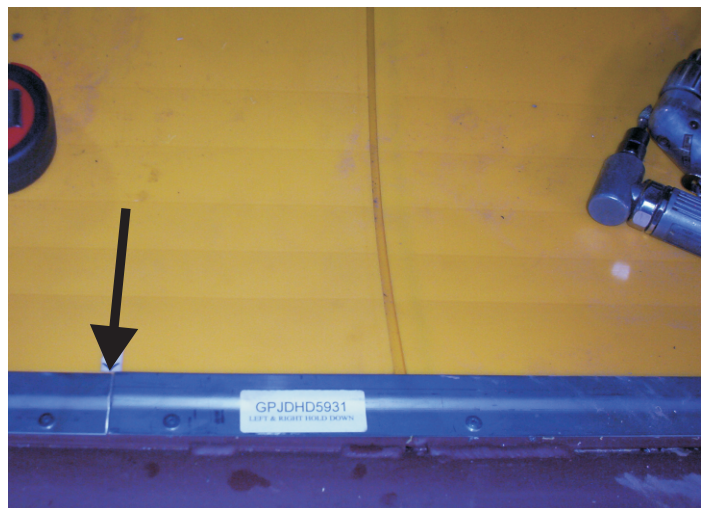

STEP 7

RE-INSTALL THE LEFT FLOOR STRIPPER.

With the center and all the left side panels secured on the leading edge and held down with the wooden shims, use the 11/32" drill bit supplied to drill the poly panels at each floor stripper mounting hole location from underneath the header as illustrated below.



Auger Removed for Illustration.

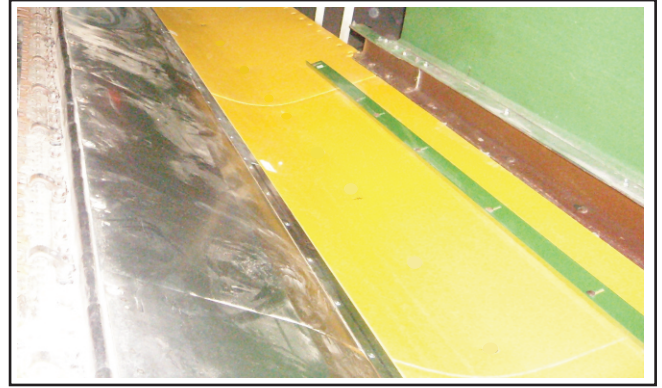

Fasten the floor stripper with the 5/16 x 1 carriage bolts supplied.

STEP 8

Remove the wooden shims and repeat the process on the right side.

STEP 9

FASTEN THE LINER ACROSS THE REAR OPENING.

Using the pre-drilled holes as a guide, drill thru with the 9/32" drill bit supplied. Secure the liner with the 1/4" drive rivets.



STEP 10

Re-adjust auger height.