

LANUDJD3000K

Installation Instructions

Unloading Auger Electric Clutch Disengage System

John Deere® 60-S670 NON HUR & 50 Series STS Combines

The initial burnish process of the clutches contained in this kit has been performed by Lankota prior to shipment.

LANKOTA®

270 West Park Avenue

Huron, SD 57350

866-526-5682

Warnings

- Do NOT use with automatic lubrication system
- Clutches must have a continuous 12V or more when in use to operate properly
- Wiring MUST be grounded directly to the battery
- Clean out grain tank sump drain WEEKLY
- After several days of non-use, re-burnish clutches using the method described in the back of the manual
- NEVER leave wet grain in grain tank

FAILURE TO FOLLOW THESE WARNINGS WILL VOID ANY AND ALL WARRANTIES, IMPLIED OR EXPRESSED.







Numerical Parts List

Part Number	Description	Qty.
LANHT9260	Wiring Harness Bundle	1
-----	Cab Extension Harness	2
-----	Power Harness	1
-----	Cab Foot Switch	1
-----	Clutch Harness	1
-----	Wiring Harness Bundle Hardware Bag	1





Numerical Parts List

Part Number	Description	Qty.
LANUDJD1001	Shaft Drill Jig	1
LANUDJD3100	Clutch Alignment Flex Bracket	1
LANUDJD3004	Door Latch Bracket	1
LANUDJD3005	Front Door Bracket	1
LANUDJD3006	Rear Door Bracket	1
LANI-5228-48	Electro Magnetic Clutch - REAR	1
LANI-5228-56	Electro Magnetic Clutch - FRONT	1
LAN60A49	#60, 49 Tooth Sprocket	2
LANUDJD1004	Sprocket Shim	6
LANFHKGV5	Key—8 x 10 x 40mm	2
LAN5218-251-016	Clutch Wire Lead	2
LANUDJDBH	Bag Of Hardware	1
-----	25/64" Drill Bit	1
-----	7/16" Lock Washer	2
-----	7/16" x 2" Grade 5 Bolt	2
-----	7/16"-14 Drill Tap	1
-----	M8-1.25 x 25mm, Grade 8.8 Bolt	16
-----	M8 Lock Washer	12
-----	M8 Nyloc Nut	4
-----	5/16" SAE Flat Washer	8
-----	11" Zip Tie	10
-----	3/8"-16 x 3/4" Carriage Bolt - (NOT USED)	2
-----	3/8"-16 x 1" Bolt - (NOT USED)	3
-----	3/8" Serrated Flange Nut - (NOT USED)	5
-----	5/8" Washer	10

Pictorial Parts List

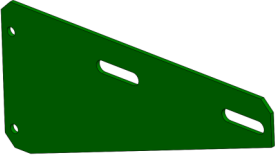
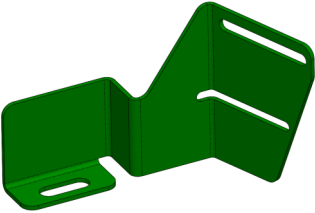
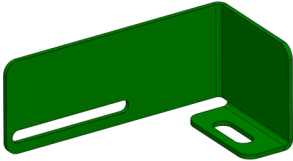
				
LANUDJD1001	LAN60A49 (2)	LANI-5228-48 (1)	LANI-5228-56 (1)	LAN5218-251-016 (2)
				
Cab Extension Harness	Power Harness	Clutch Harness	Cab Foot Switch	Wiring Kit Bag of Hardware
				
LANUDJD3100 (1)	M8 Lock Washer (12)	7/16" Lock Washer (2)	7/16"-14 Tap	25/64" Drill Bit
				
M8-1.25 X 25mm, Gr 8.8 Bolt (16)	M8 Nyloc Nut (4)	5/16" SAE Flat Washer (8)	7/16" x 2" Grade 5 Bolt (2)	11" Zip Tie (10)

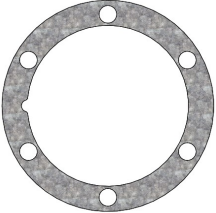
Pictorial Parts List

 <p>LANUDJD3004</p>	 <p>LANUDJD3005</p>	 <p>LANUDJD3006</p>	 <p>8x10 x 40mm Key (2)</p>	 <p>LANUDJD1004 (6)</p>
 <p>5/8" SAE Flat Washer (10)</p>				

Preparation

Refer To Figure 1.1

1. Open L/H main access door on combine, exposing the unloading auger drive chain system.
2. Loosen drive chain tensioner completely.
3. Remove drive chain; let it hang from rear main drive sprocket or set it aside for later reinstallation.
4. Remove both grain tank cross auger drive sprockets from auger shafts. Leave bearing locking collar and square shaft key installed on shafts just as they are. **DO NOT TRY TO REMOVE BEARING LOCKING COLLAR OR SQUARE KEY FROM SHAFT!**
5. Use emery cloth to clean any scuffs, burs or paint from end of shaft. This will make installation of new components much easier.

Figure 1.1



1. Clutch & Sprocket Installation

Refer To Figure 1.2

1. Locate the 25/64" Drill Bit that is supplied in the bag of hardware. Measure from the cutting end of the drill bit back towards the shank 3" inches and make a visible mark.
2. Slide Shaft Drill Jig (LANUDJD1001) over the end of front exposed auger shaft. Make sure jig is on all the way.

Refer To Figure 1.3

3. Using the jig as a guide, drill into the end of the shaft deep enough so that your 3" mark is flush with the end of the Shaft Drill Jig. **MAKE SURE YOU DRILL AT LEAST THIS DEEP. IF YOU DRILL DEEPER THAT IS OK.**
4. Repeat these steps for the second, rear auger shaft.
5. Remove Shaft Drill Jig from shaft. You will no longer use this jig.

Figure 1.2



Figure 1.3

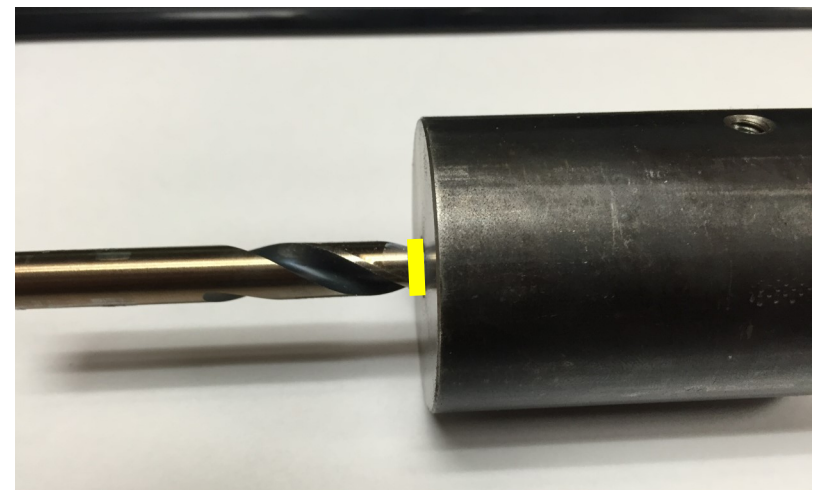

1. Clutch & Sprocket Installation

Refer To Figure 1.4

6. Use a pipe wrench or equivalent to hold auger shaft from turning while tapping the drilled hole. Locate the 7/16" Tap supplied in the hardware bag and tap the holes drilled in both auger shafts. Make sure the threads are a minimum 1-1/4" deep.
7. Use a cutting oil or spray lubricant if possible to get the best thread results.

Figure 1.4



1. Clutch & Sprocket Installation

Refer To Figure 1.5

8. Locate twelve of the M8-1.25 x 25mm, Grade 8.8 Bolts and twelve of the M8 Lock Washers from the supplied bag of hardware. Attach a #60, 60 Tooth Sprocket (LAN60A60) to the Electro Magnetic Clutch (LANI-5228-48) using six bolts and lock washers - This will go on the **REAR CROSS AUGER**.
9. Attach another sprocket to the Electro Magnetic Clutch (LANI-5228-56) using the remaining fasteners - This will go on the **FRONT CROSS AUGER**.

NOTE: Bolts may be tightened at this time.



Figure 1.5

1. Clutch & Sprocket Installation

Refer to Figure 1.6 & 1.7

NOTES:

- Shims (LANUDJD1004) are provided to bolt between the clutch and sprocket and 5/8" washers are provided to place between the clutch and auger shaft. *NOTE: You may not need to use any of these. The installer needs to make sure all sprockets run on the same plane and line up with the chain properly.*
 - It is **STRONGLY** recommended that anti-seize be applied to the auger shaft before installing the clutch & sprocket assembly.
 - Use a small amount of thread locking compound on each bolt to secure clutch/sprocket assembly to drilled shafts.
10. Install both front and rear clutch/sprocket assemblies onto drilled auger shafts using one 7/16" x 2" Grade 5 Bolt with thread locking compound and one 7/16" Lock Washer per shaft.
 11. Re-install the unloading system chain on the new sprocket/clutch assemblies.

Figure 1.6



Figure 1.7

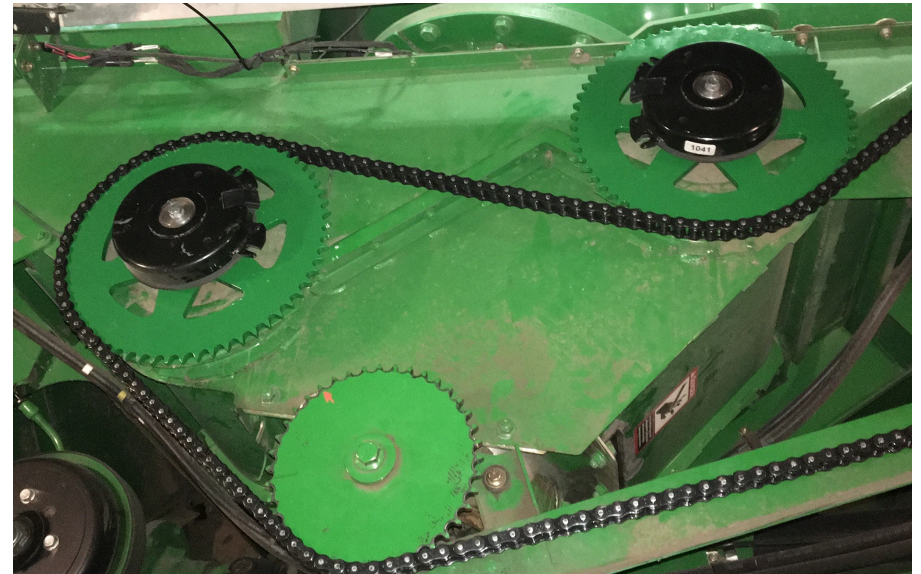

1. Clutch & Sprocket Installation

Refer to Figure 1.8 & 1.9

12. Locate four M8-1.25 x 25mm, Grade 8.8 Bolts, four M8 Nyloc Nuts and eight 5/16" SAE Flat Washers from the supplied bag of hardware and use to attach Clutch Alignment Bracket (LANUDJD3002) to both front and rear clutch assemblies. Tighten at this time.
13. Plug a clutch wire lead (LAN5218-251-016) into each of the clutches
14. Tighten the unload drive chain as outlined in the COMBINE OPERATOR'S MANUAL.

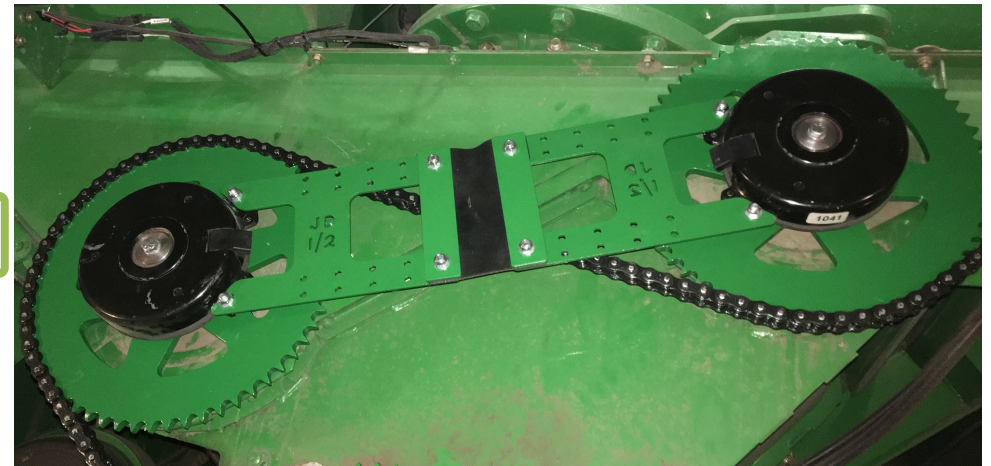

Figure 1.8

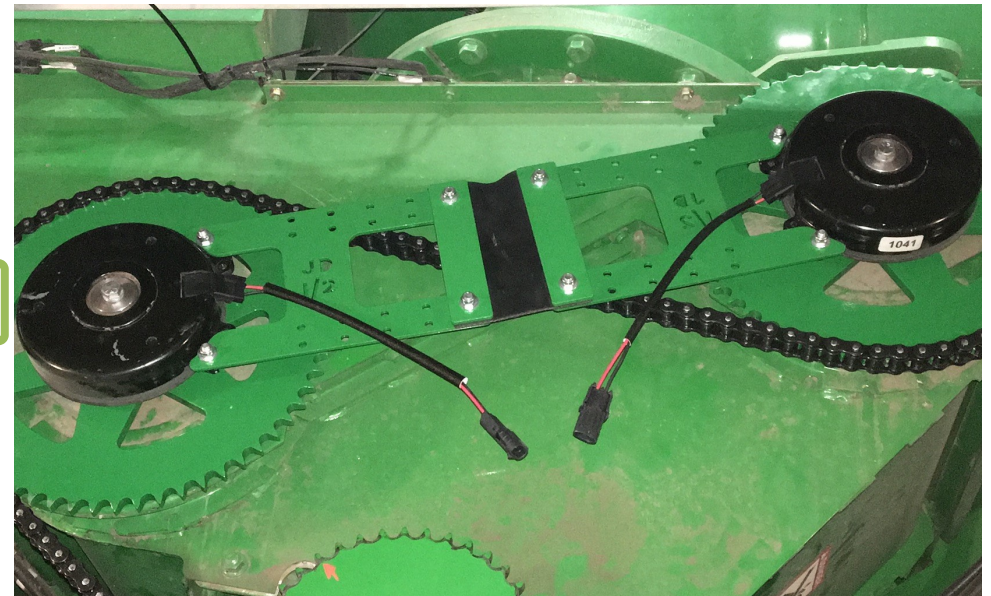

Figure 1.9

2. Rear Wiring Harness Installation

Refer to Figure 2.1

1. Open the wiring harness box and unpack.

Figure 2.1

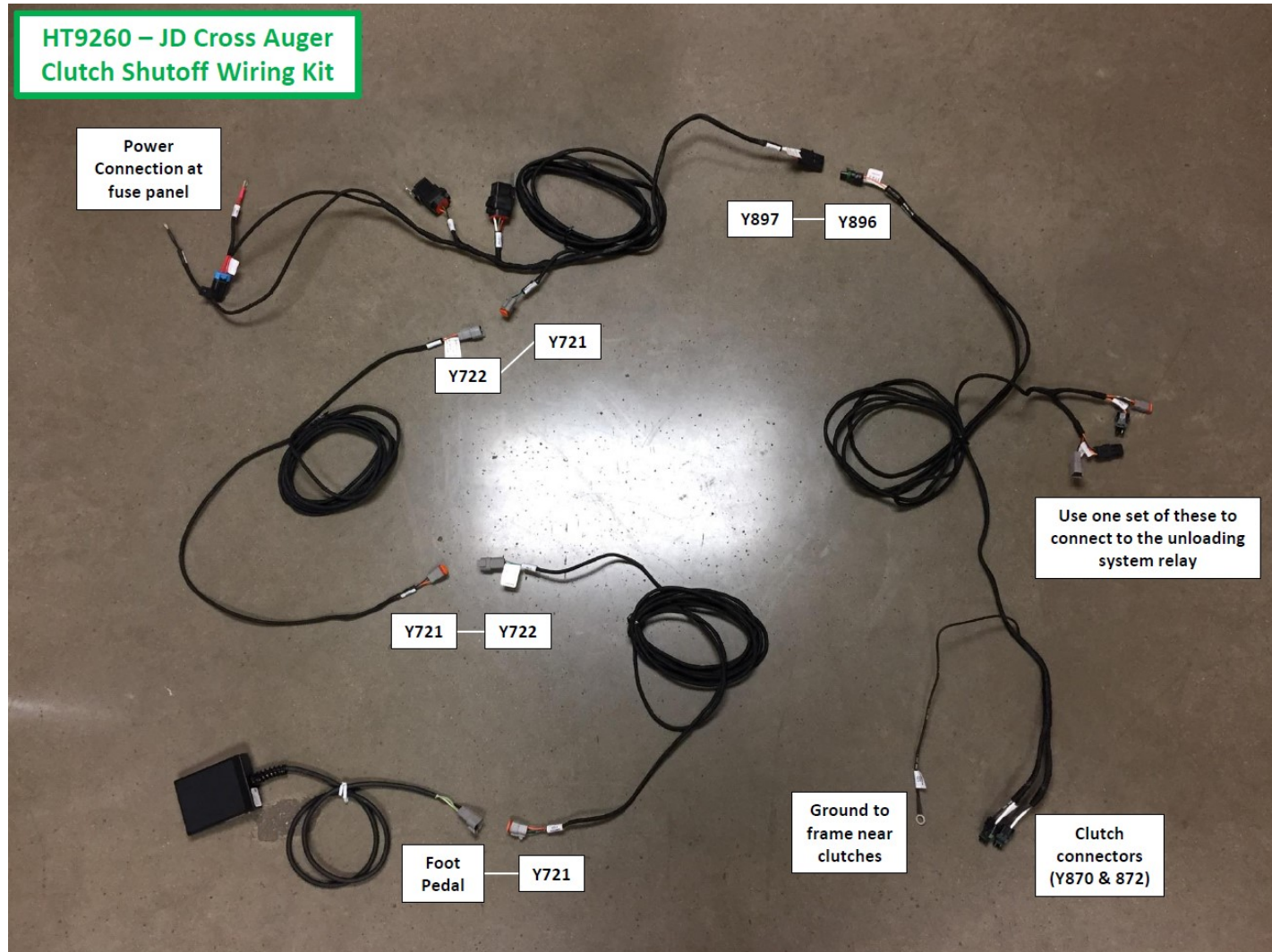

2. Rear Wiring Harness Installation

Refer to Figures 2.2 - 2.4

2. Identify the power cable and connect the red wire to the battery cable terminal. This may look different depending on your model of combine - see Figures 2.2a - 2.2c.

Figure 2.2a

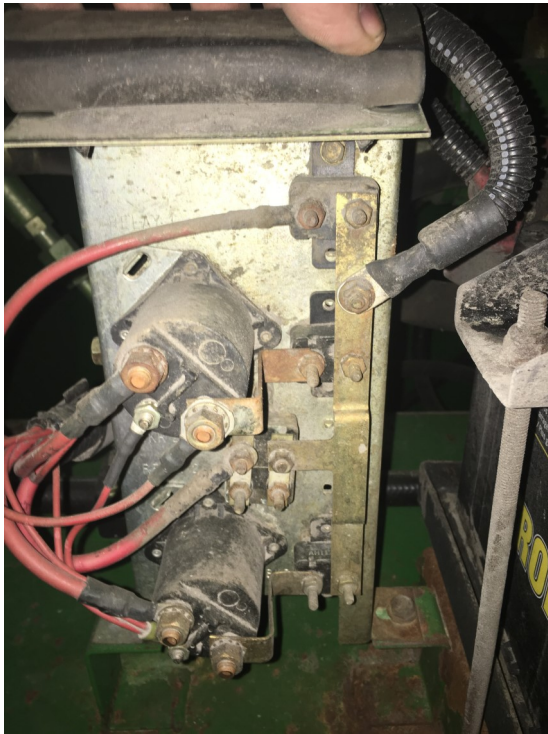

Figure 2.2b

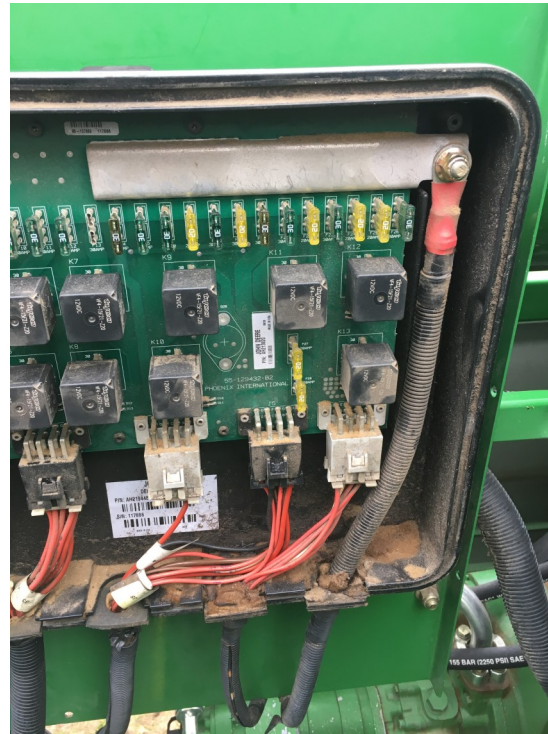

Figure 2.2c



2. Rear Wiring Harness Installation

Refer to Figures 2.3 & 2.4

3. Attach the relays near the fuse panel using the included attachment plate and existing hardware.
4. Connect the ground wire to the negative battery terminal.

Figure 2.3



Figure 2.4



2. Rear Wiring Harness Installation

Refer to Figures 2.5 & 2.6

5. Connect one of the cab extension cords to the power cable.
6. Run the ends of the two cords together across the combine, under the rotor drive belt and on top of the sieve.

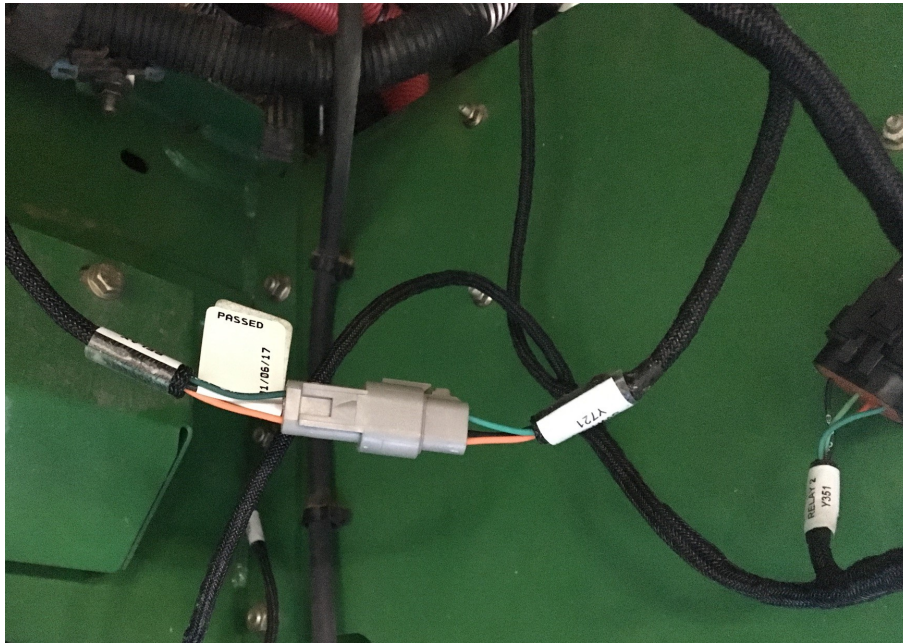

Figure 2.5



Figure 2.6

2. Rear Wiring Harness Installation

Refer to Figure 2.7

The supplied wiring harness has two different style connector ends to fit many different model combines. Choose either the black connectors or the gray connectors that match your combines connectors.

7. Retrieve the clutch connecting wiring harness.
8. Access the engine compartment.
9. Locate the unloading auger solenoid wiring connectors on the left side of the engine.

Figure 2.7

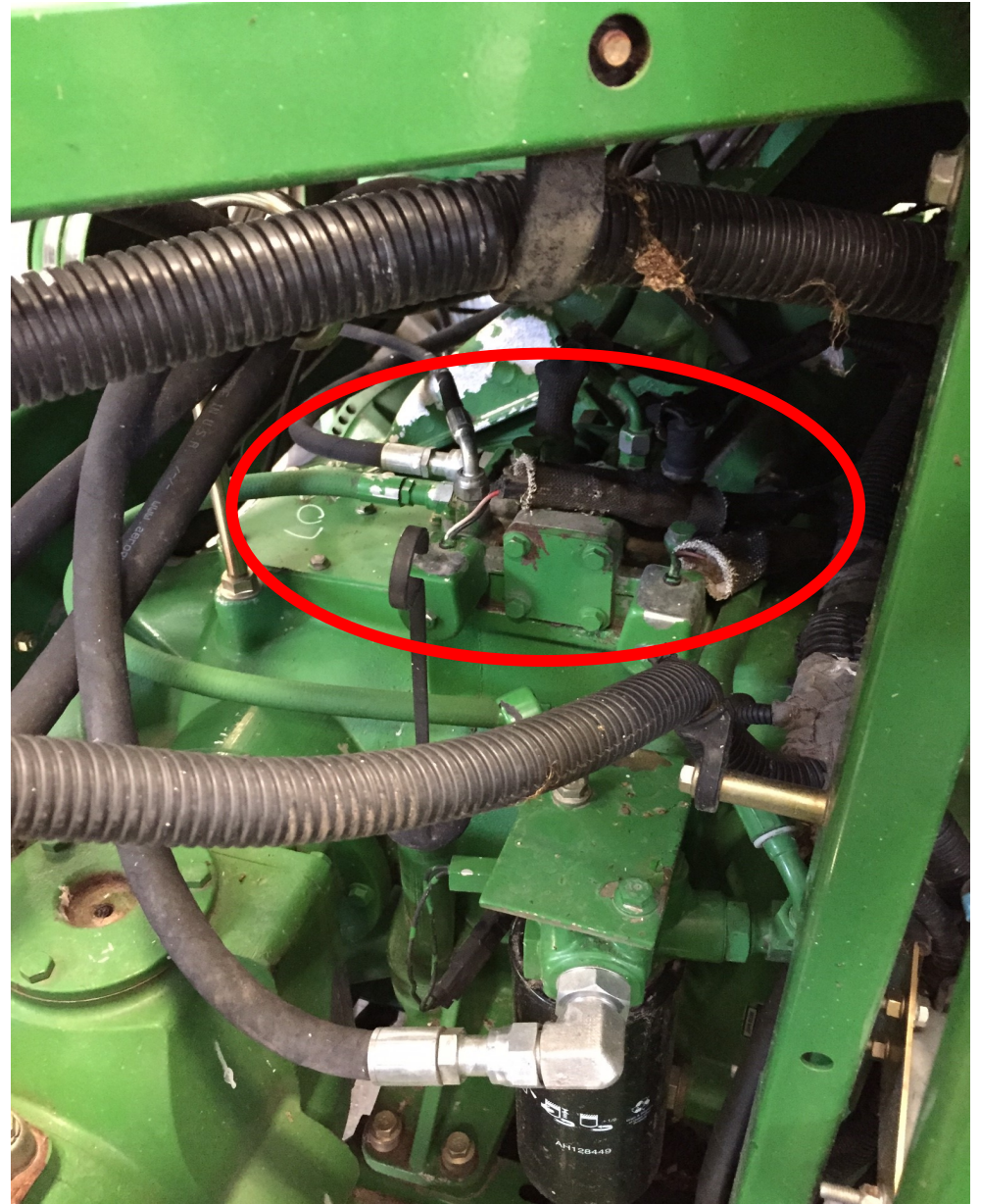

2. Rear Wiring Harness Installation

Refer to Figure 2.8 & 2.9

The supplied wiring harness has two different style connector ends to fit many different model combines. Choose either the black connectors or the gray connectors that match your combine's.

10. Loosen protective covering on L/H solenoid.

11. Disconnect **L/H ONLY** wiring connectors as shown in Figure 2.3.

Figure 2.8



Figure 2.9

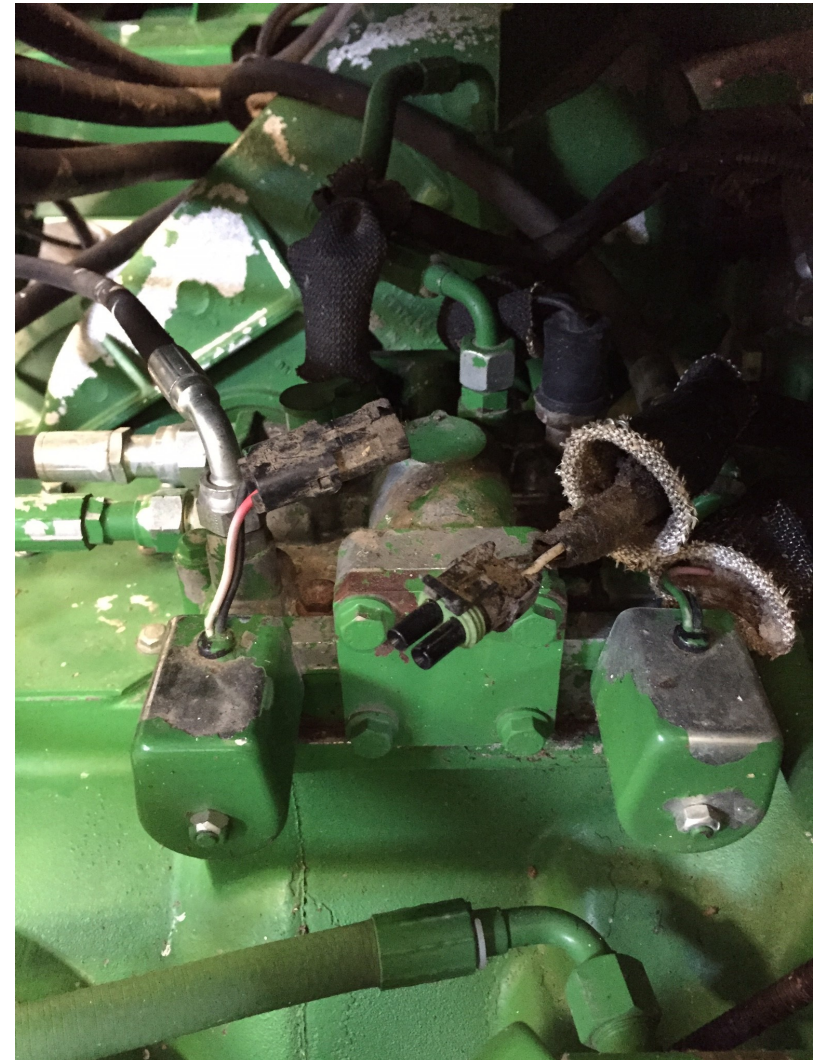

2. Rear Wiring Harness Installation

Refer to Figure 2.10

12. Connect either the black connectors or the gray connectors of the wiring harness to the connectors on the combine. Whichever connectors do not get used, connect those together as shown in the picture shown by the yellow arrow.
13. Replace wiring harness protective cover previously removed. Secure with a zip tie.

Route wiring harness as shown in the next figures. Secure harness as needed using supplied bag of hardware that came in the wiring bundle and/or the supplied zip ties.

Figure 2.10



2. Rear Wiring Harness Installation

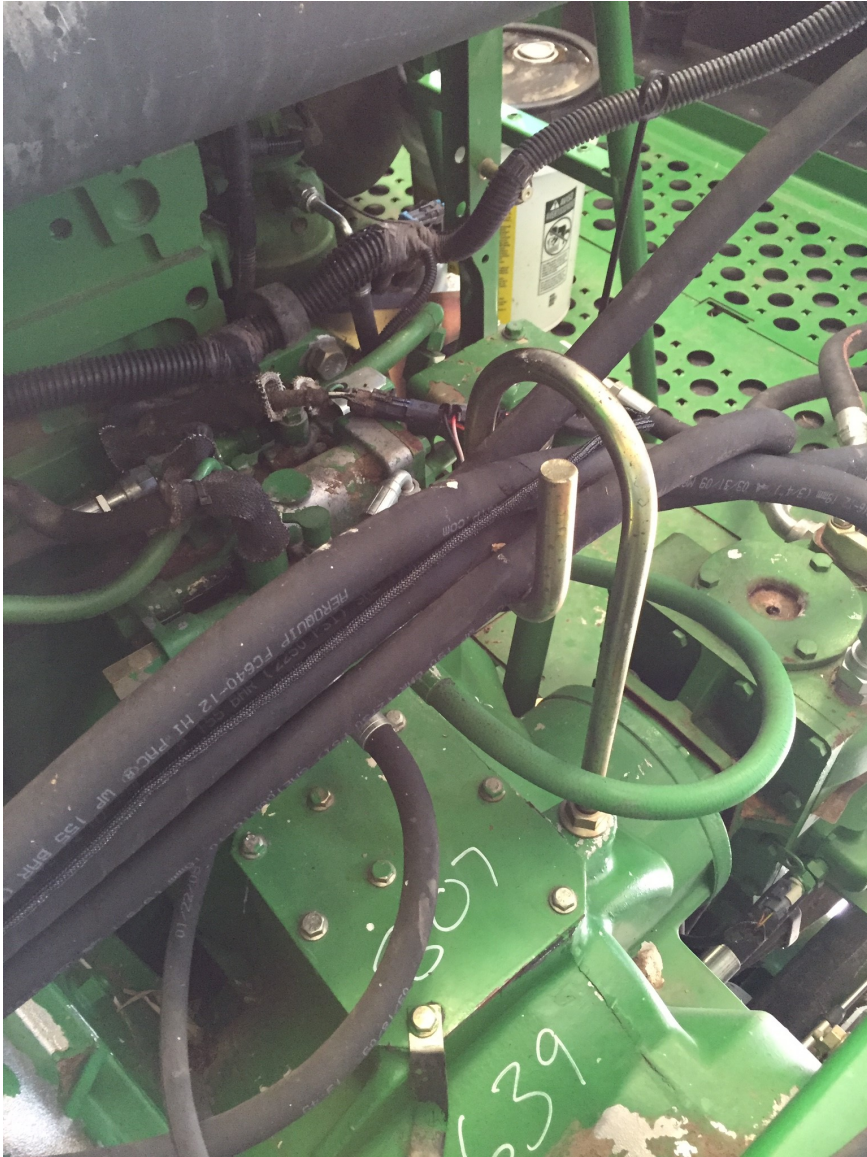

2. Rear Wiring Harness Installation

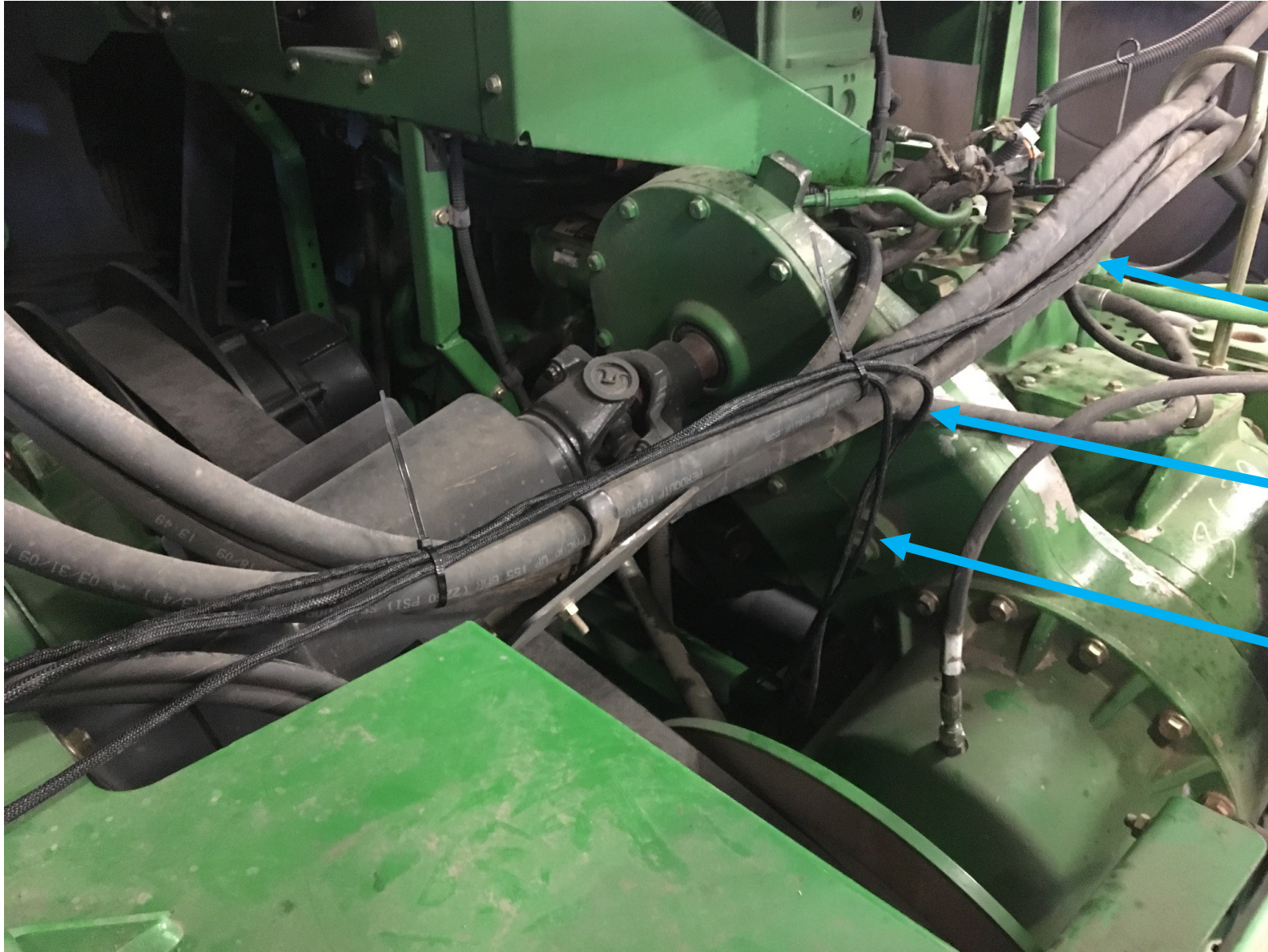

Clutch Connector
Wiring Harness

Cab Extension
Cable

Power Cable
Wiring Harness

2. Rear Wiring Harness Installation



2. Rear Wiring Harness Installation

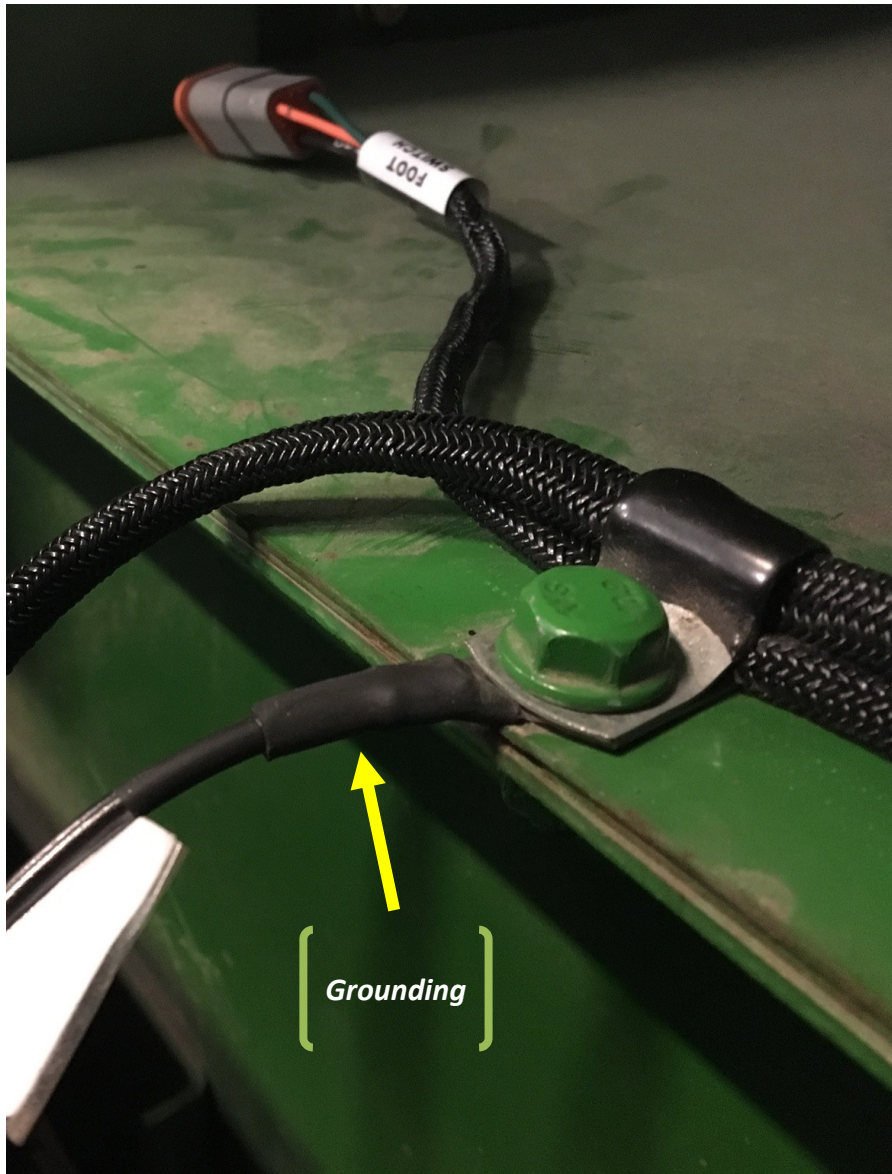

Grounding

Figure 2.11

Refer to Figures 2.11 & 2.12

14. Attach grounding cable to frame (ensure a good connection).
15. Route the clutch harness to the clutches and plug into the clutch wire leads (LAN5218-251-016).
16. Secure harness with zip ties as to avoid any damage.

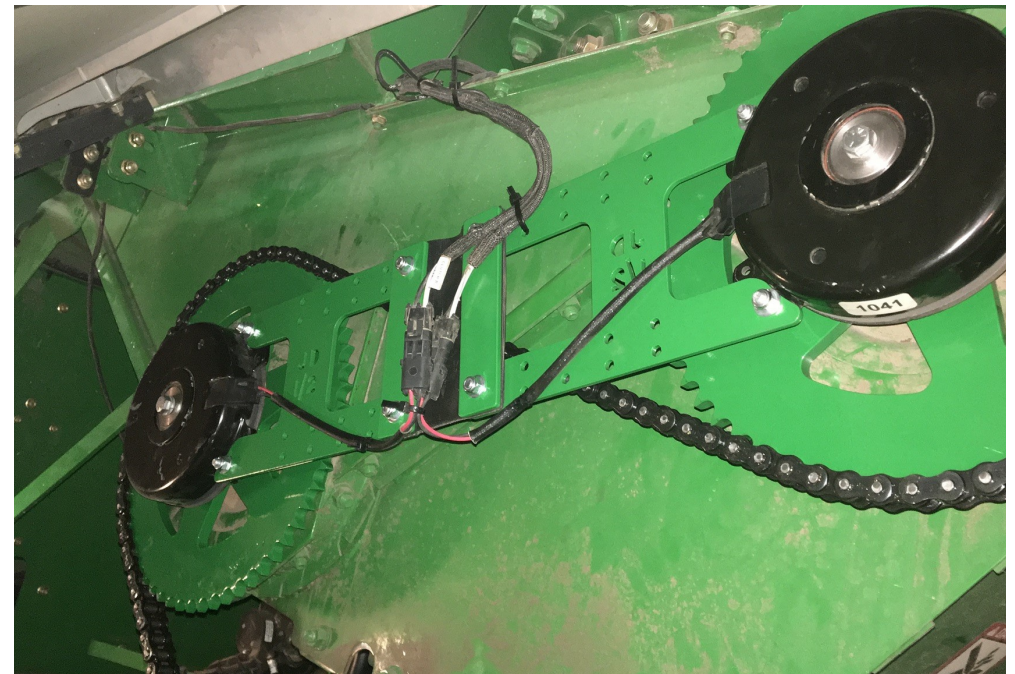

Figure 2.12

3. Cab Wiring Harness Installation

Refer to Figures 3.1 & 3.2

1. Retrieve second cab extension wiring harness and connect it to the first as shown.
2. Attach harness where you can to avoid any damage during operation of combine and/or opening and closing of the side shield.



Figure 3.1

Figure 3.2



3. Cab Wiring Harness Installation

Refer to Figure 3.3 & 3.4

3. Open lower access door just outside of the combine cab door at the top of the ladder landing.
4. Route harness as shown in Figure 3.3. Secure where you can with zip ties.
5. Loop any extra wire here.

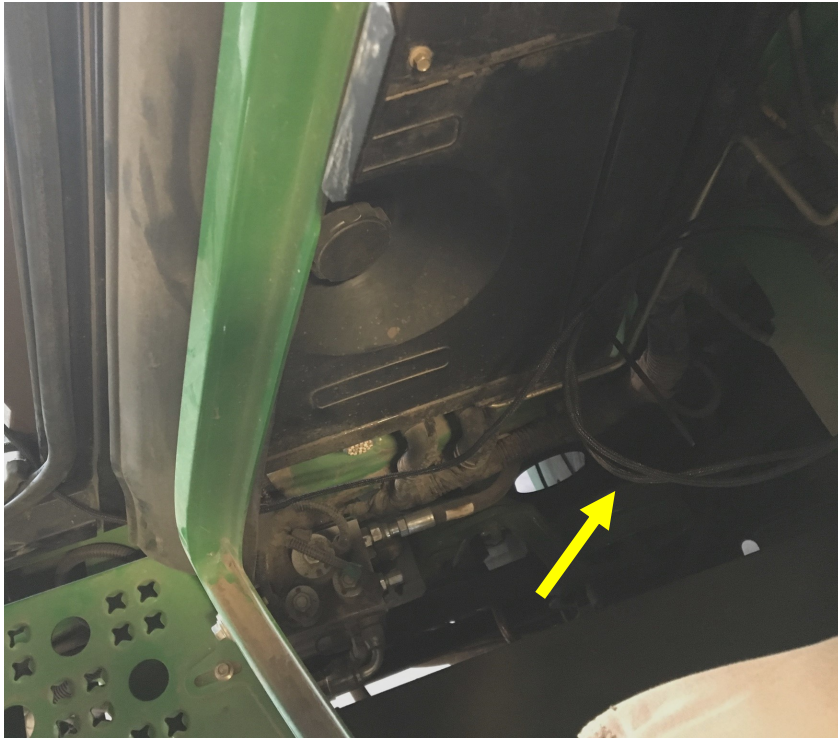

Figure 3.4

Figure 3.3



3. Cab Wiring Harness Installation

Refer to Figure 3.5A

6. Run harness through bottom of door frame as shown. Notice harness under door seal.

Refer to Figure 3.5B

7. It is recommended to grind out a small amount of material from the door frame so the harness does not experience a tight bend and rub on the metal over time causing the harness to fail.

Figure 3.5B



Figure 3.5A



3. Cab Wiring Harness Installation

Refer to Figure 3.6

8. Remove cab door bottom threshold cover by removing the three recessed bolts.
9. Pull up floor mat of combine cab just in front of passenger and operator seat. Run harness under floor mat to the far R/H side of the cab.
10. Connect Floor Pedal Harness to the cab extension cord. Place in cab where desired. Route cord as best as possible to avoid congestion with feet and brake pedals.



Figure 3.7

Figure 3.6



4. Door Bracket Installation

In some instances the side of the combine may come in contact with the clutches when closed. Replacement door brackets are provided to space the door out an appropriate amount in the front, back, and at the latch area of the door.

Refer To Figures 4.1 & 4.2

1. Open the door and remove the middle door latch and bracket plate.
2. Replace plate with LANUDJD3004 as shown and reattach to combine. Adjust it so that the door still latches properly but does not come into contact with any portion of the clutches.

Figure 4.1



Figure 4.2



4. Door Bracket Installation



Figure 4.3a



Figure 4.3b

Refer To Figures 4.3 - 4.4

3. Remove the rear door catch plate from the combine.
4. Remove the magnetic cup from the door.



Figure 4.4a



Figure 4.4b

4. Door Bracket Installation

Refer To Figures 4.5

5. Replace rear plate with LANUDJD3006 as shown and reattach to combine. Adjust the plate so that the door rests firmly against it when latched.

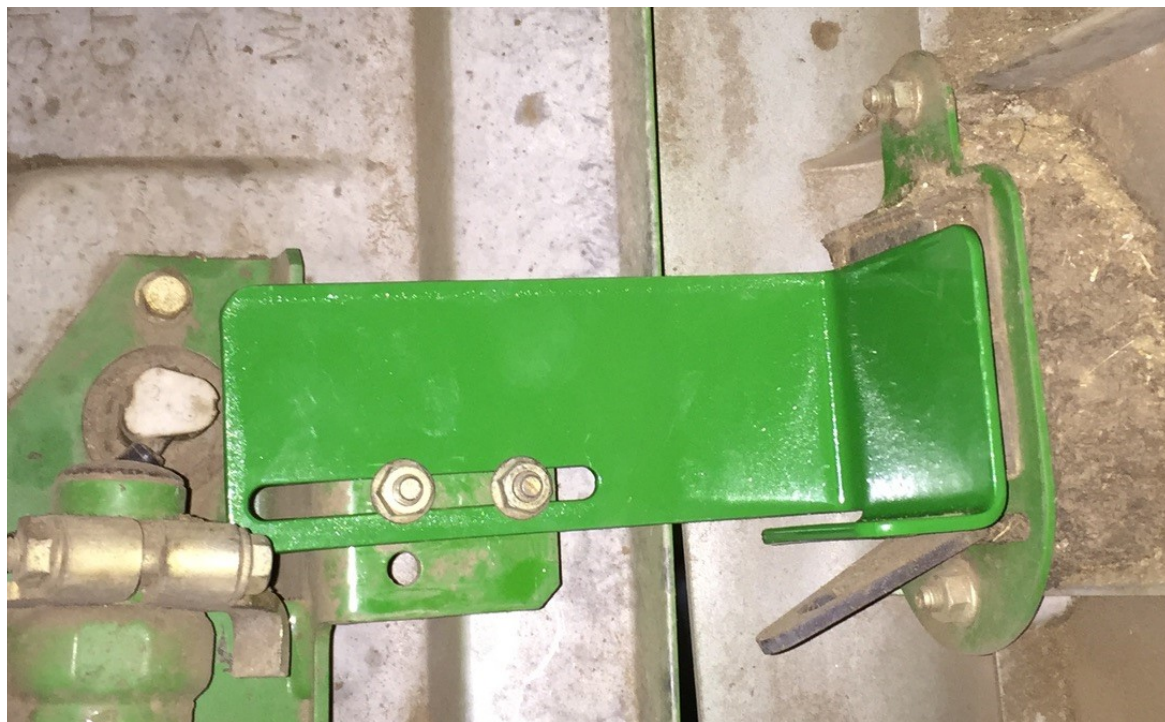

Figure 4.5

4. Door Bracket Installation

Refer To Figures 4.6 - 4.8

6. Remove the front door bracket.
7. Replace with LANUDJD3005. Adjust it so that the door rests firmly against it when latched.



Figure 4.6



Figure 4.7



Figure 4.8

FOOT SWITCH Y721					
PIN	CIR #	LABEL	COLOR	GA	TYPE
A	001	GROUND	BLK	18	TXL
B	728	AUX SWITCH	DK GRN	18	TXL
C	719	12V ENABLE	ORG	18	TXL

RELAY ASSM Y722					
PIN	CIR #	LABEL	COLOR	GA	TYPE
A	001	GROUND	BLK	18	TXL
B	728	AUX SWITCH	DK GRN	18	TXL
C	719	12V ENABLE	ORG	18	TXL

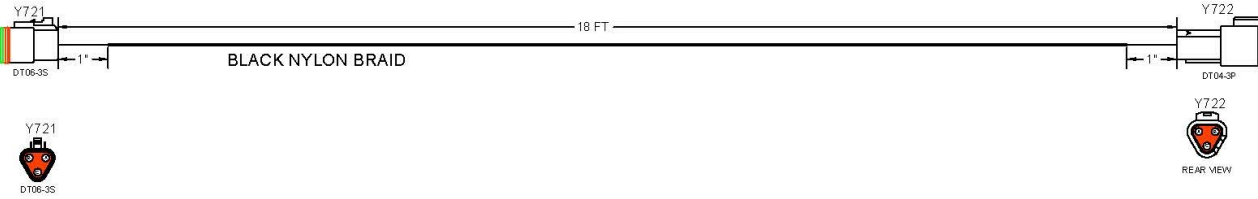

- 2 TXL WIRE INSULATION MAY NOT EXCEED 0.078" (2MM) DIA.
- 1 LABEL EACH CONNECTOR WITH PART ID AND NAME

ID LABEL	
OWNER	HEADSIGHT, INC
ITEM	SEE SHEET PART NUMBER
REVISION	SEE SHEET REV. #
DATE	BUILD DATE
MFG	SUPPLIER NAME

COMPONENT DATA							
ITEM	PART ID	QTY	DESCRIPTION	MFG	MFG PN	TERMINAL PN	ACCESSORY PN
1							
2	Y721	1	CONN, 3p PLUG	DEUTSCH	DT06-3S	0462-201-16141	W3S
3	Y722	1	CONN, 3p RCPT	DEUTSCH	DT04-3P	0460-202-16141	W3P
4							
5							
6							
7							
8							
9							
10							

NOTES:
 FOOT SWITCH EXTENSION
 1 NEEDED FOR 9x70--S
 2 NEEDED FOR 9x00-9x50

REVISIONS			
REV	DESCRIPTION	DATE	APPROVED
1	CREATED PART	12.2.16	JHK
2	CORRECTED BLACK-A, ORG-C	01.04.17	JHK



FILE NAME	HT9260-FS	
	CABLE LAYOUT	
PART NUMBER	HT9260-FS	REV 2
SCALE	NOT TO SCALE	SHEET 01



NOTES:	REVISIONS					FILE NAME	
	REV	DESCRIPTION	DATE	APPROVED		HT9260-FS R2	
						WIRING SCHEMATIC	
						PART NUMBER	REV
						HT9260-FS	2
				DRAWN 1/4/2017	SCALE NOT TO SCALE		
				DRAWN BY: JHK	SHEET 02		

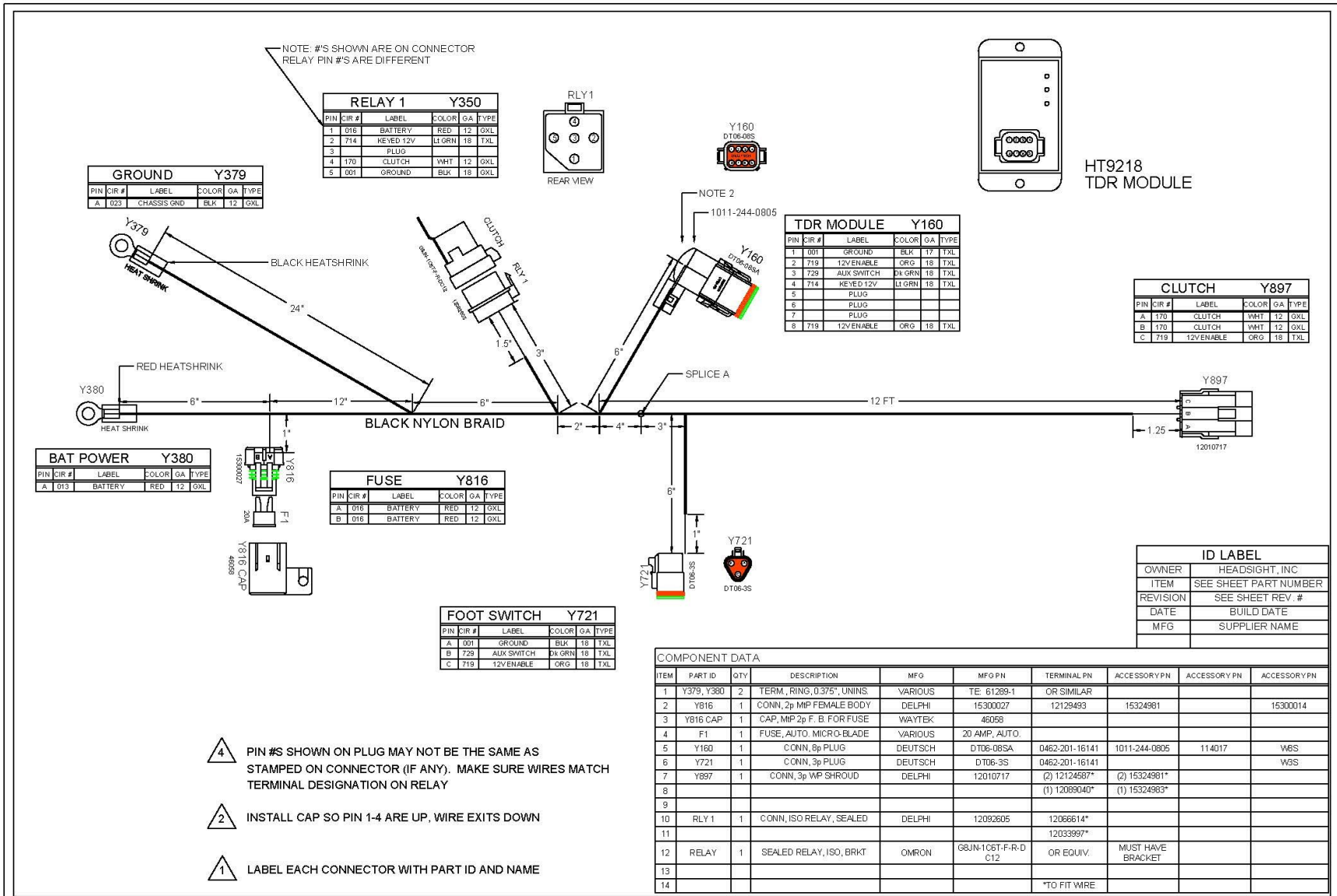

NOTES:
LANKOTA CLUTCH ADAPTER

REVISIONS			
REV	DESCRIPTION	DATE	APPROVED
4	SEALED RELAYS, BAT POWER	12.2.16	JHK
5	TDR MODULE Y160	2.2.18	JHK

HEADSIGHT
HARVESTING SOLUTIONS

DRAWN 7/31/2018
DRAWN BY: JHK

FILE NAME	HT9260-CAB R5 CLUTCH CABLE LAYOUT	
PART NUMBER	HT9260-CAB	REV 5
SCALE	NOT TO SCALE	SHEET 01

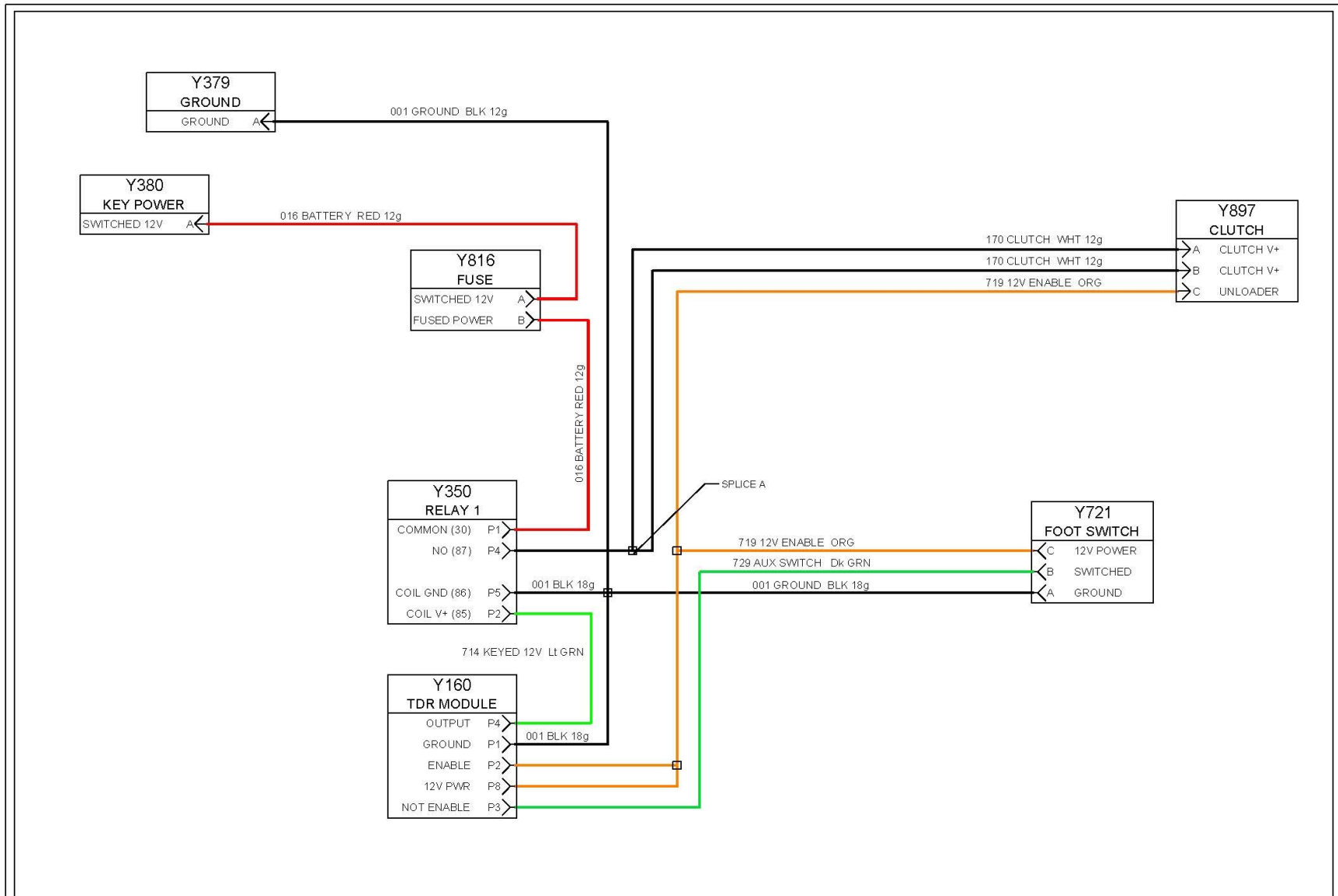

NOTES:
LANKOTA CLUTCH ADAPTER

REVISIONS				
REV	DESCRIPTION	DATE	APPROVED	

HEADSIGHT
 HARVESTING SOLUTIONS

DRAWN 7/31/2018
 DRAWN BY: JHK

FILE NAME HT9260-CAB R5 CLUTCH WIRING SCHEMATIC	
PART NUMBER HT9260-CAB	REV 5
SCALE NOT TO SCALE	SHEET 02

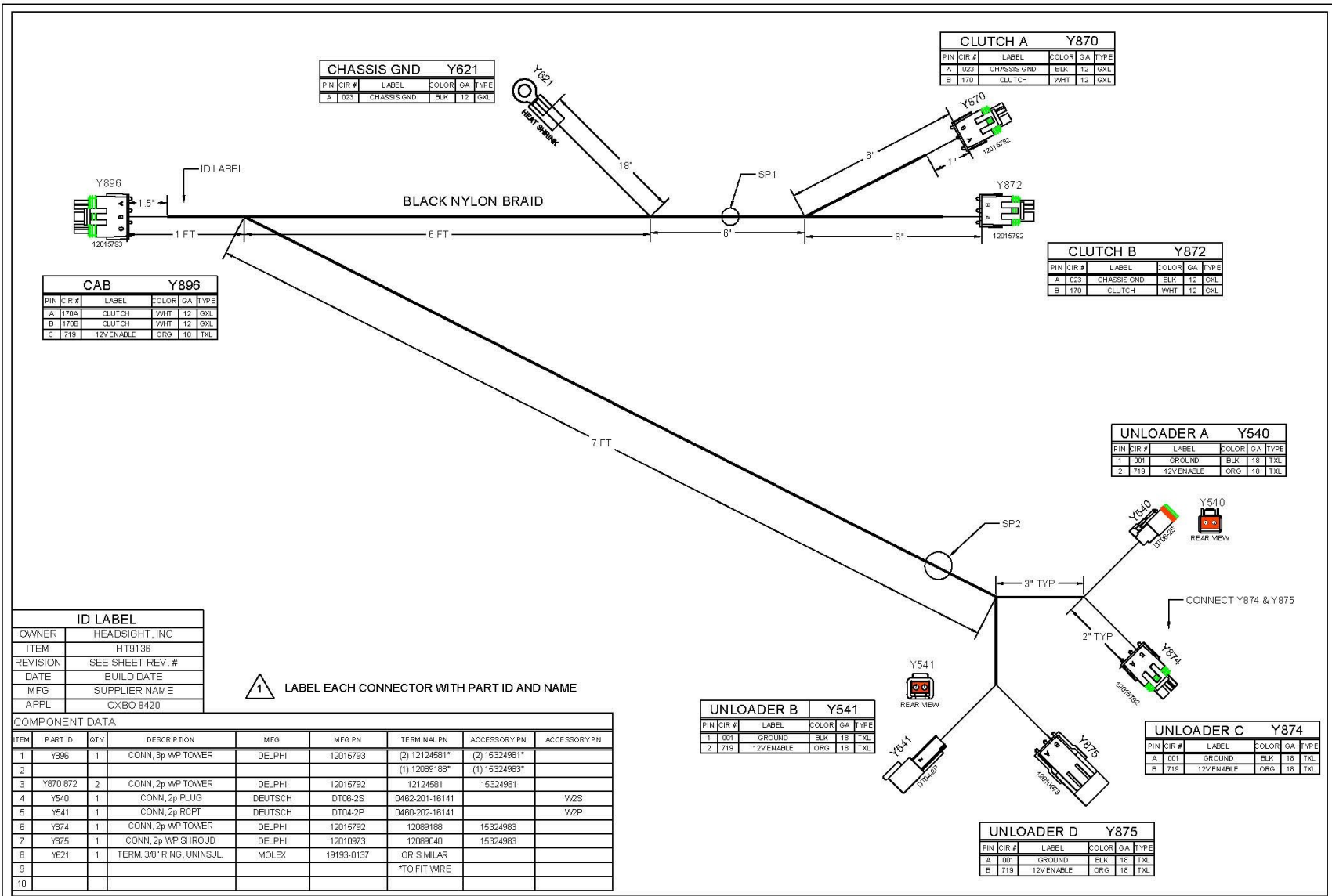

ID LABEL	
OWNER	HEADSIGHT, INC
ITEM	HT9136
REVISION	SEE SHEET REV. #
DATE	BUILD DATE
MFG	SUPPLIER NAME
APPL	OXBO 8420

1 LABEL EACH CONNECTOR WITH PART ID AND NAME

COMPONENT DATA							
ITEM	PART ID	QTY	DESCRIPTION	MFG	MFG PN	TERMINAL PN	ACCESSORY PN
1	Y896	1	CONN, 3p WP TOWER	DELPHI	12015793	(2) 12124581*	(2) 15324981*
2						(1) 12089188*	(1) 15324983*
3	Y870, 872	2	CONN, 2p WP TOWER	DELPHI	12015792	12124581	15324981
4	Y540	1	CONN, 2p PLUG	DEUTSCH	DT06-2S	0462-201-16141	W2S
5	Y541	1	CONN, 2p RCPT	DEUTSCH	DT04-2P	0460-202-16141	W2P
6	Y874	1	CONN, 2p WP TOWER	DELPHI	12015792	12089188	15324983
7	Y875	1	CONN, 2p WP SHROUD	DELPHI	12010973	12089040	15324983
8	Y621	1	TERM, 3/6" RING, UNINSUL	MOLEX	19193-0137	OR SIMILAR	
9						*TO FIT WIRE	
10							

NOTES:
LANKOTA CLUTCH ADAPTER

REVISIONS			
REV	DESCRIPTION	DATE	APPROVED
4	GROUND. WIRE ROUTING	12.2.16	JHK

HEADSIGHT
HARVESTING SOLUTIONS

DRAWN 12/2/2016
DRAWN BY: JHK

FILE NAME	HT9260-CL R4 CLUTCH CABLE LAYOUT	
PART NUMBER	HT9260-CL	REV 4
SCALE	NOT TO SCALE	SHEET 01

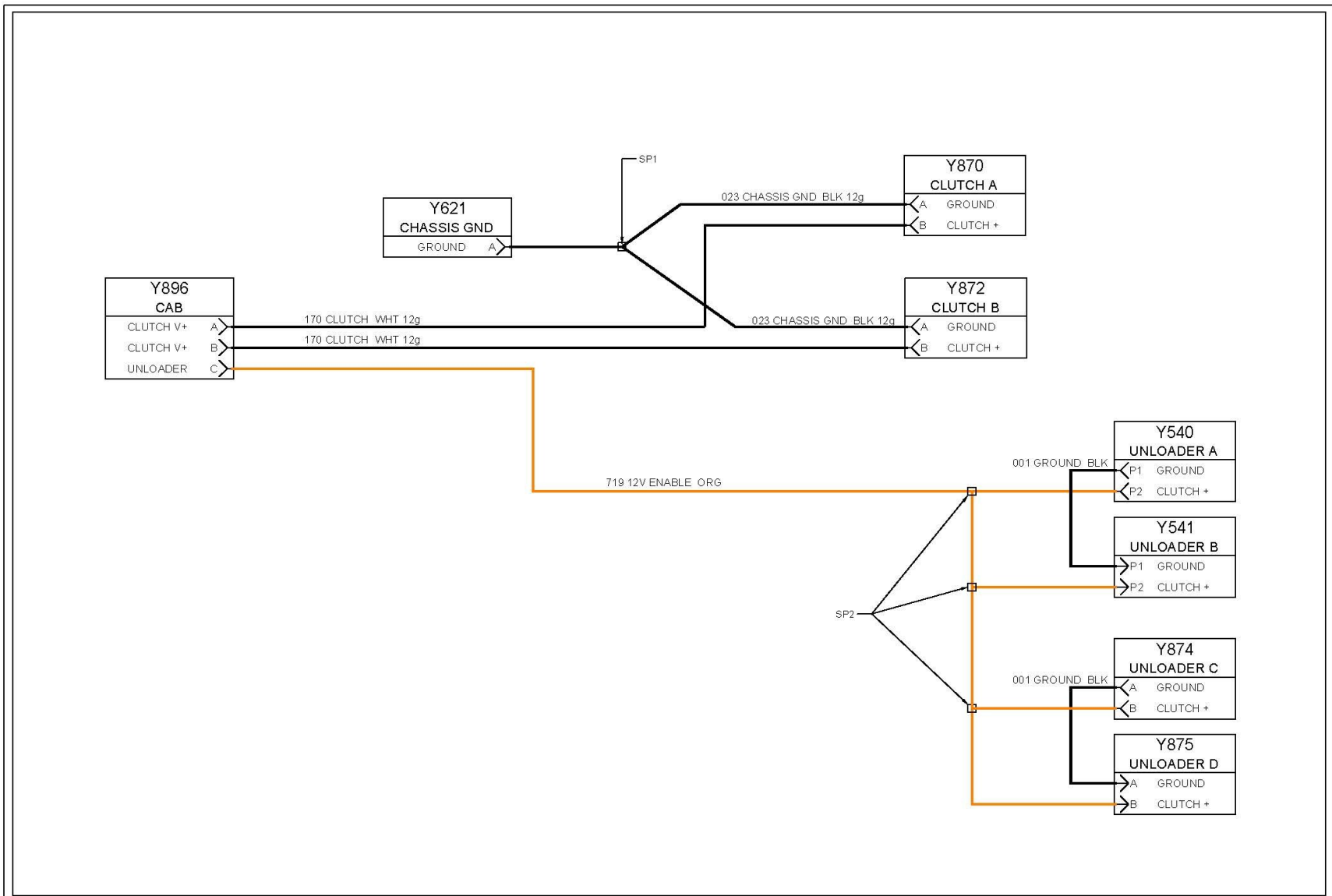

NOTES: LANKOTA CLUTCH ADAPTER	REVISIONS				 HEADSIGHT HARVESTING SOLUTIONS	FILE NAME HT9260-CL R4 CLUTCH WIRING SCHEMATIC	
	REV	DESCRIPTION	DATE	APPROVED		PART NUMBER HT9260-CL	REV 4
DRAWN 12/2/2016				SCALE NOT TO SCALE		SHEET 02	
DRAWN BY: JHK							

Finishing Up

1. Make one final check to complete wiring harness to ensure there are no points in the harness that will come in contact with anything that may damage harness during combine operation and/or L/H main access door opening and closing.
2. Do a final check of all nuts, bolts etc. installed to make sure they are all tight and secure.

Test Run

Test run the system. The unloading auger system should work exactly the same as it did before you installed this kit except when the foot switch is engaged the two grain tank cross augers will stop turning allowing the unloading auger to empty out roughly 85 - 90%. As soon as pressure is released from the foot switch, the augers will reengage. This means that anytime you want the cross augers not to turn, you must have your foot on the foot switch.

The initial burnish process of the clutches contained in this kit has been performed by Lankota prior to shipment. Seasonal reburnishing of the clutches at the beginning of every harvest season will greatly increase the life of your clutch system.

To burnish the clutches:

1. Swing out the auger.
2. Start the unloading auger.
3. Run combine on high idle.
4. Press and release the foot switch 5-10 times.