



TITAN™ SERIES

2967-029 SHORT U.N.T.™

2967-097 SHORT U.N.T.™ CNH
RESIDUE MANAGER

OPERATOR'S MANUAL PART IDENTIFICATION

2565-696_REV_G - 09/2015



YETTER MANUFACTURING CO.
FOUNDED 1930

Colchester, IL 62326-0358

Toll free: 800/447-5777

309/776-3222 (Fax)

Website: www.yetterco.com

E-mail: info@yetterco.com

YETTER

FOREWORD

You've just joined an exclusive but rapidly growing club.

For our part, we want to welcome you to the group and thank you for buying a Yetter product.

We hope your new Yetter products will help you achieve both goals-increase your productivity and increase your efficiency so that you may generate more profit.

This operator's manual has been designed into four major sections: Foreword, Safety Precautions, Installation Instructions and Parts Breakdown.



This **SAFETY ALERT SYMBOL** indicates important safety messages in the manual. When you see this symbol, be alert to the possibility of **PERSONAL INJURY** and carefully read the message that follows.

The word **NOTE** is used to convey information that is out of context with the manual text. It contains special information such as specifications, techniques and reference information of a supplementary nature.

The word **IMPORTANT** is used in the text when immediate damage will occur to the machine due

to improper technique or operation. Important will apply to the same information as specified by note only of an immediate and urgent nature.

It is the responsibility of the user to read the operator's manual and comply with the safe and correct operating procedure and to lubricate and maintain the product according to the maintenance schedule in the operator's manual.

The user is responsible for inspecting his machine and for having parts repaired or replaced when continued use of the product would cause damage or excessive wear to the other parts.

It is the user's responsibility to deliver his machine to the Yetter dealer who sold him the product for service or replacement of defective parts, which are covered by the warranty policy.

If you are unable to understand or follow the instructions provided in this publication, consult your local Yetter dealer or contact:

YETTER MANUFACTURING CO.

309/776-4111

800/447-5777

309/776-3222 (FAX)

Website: www.yetterco.com

E-mail: info@yetterco.com

WARRANTY

Yetter Manufacturing warrants all products manufactured and sold by it against defects in material. This warranty being expressly limited to replacement at the factory of such parts or products as shall appear to be defective after inspection. This warranty does not obligate the Company to bear cost of labor in replacement of parts. It is the policy of the Company to make improvements without incurring obligations to add them to any unit already sold. No warranty is made or authorized to be made, other than herein set forth. This warranty is in effect for one year after purchase.

DEALER: _____

Yetter Manufacturing warrants its own products only and cannot be responsible for damages to equipment on which mounted.

TABLE OF CONTENTS

Introduction.....	2
Warranty.....	2
Table of Contents.....	3
Optional Equipment.....	3
Bolt Torque.....	4
Operation.....	5-6
Planter Adjustment.....	7
Installation Instruction.....	8-10
Maintenance.....	11-16
Parts Identification.....	17-18

OPTIONAL EQUIPMENT

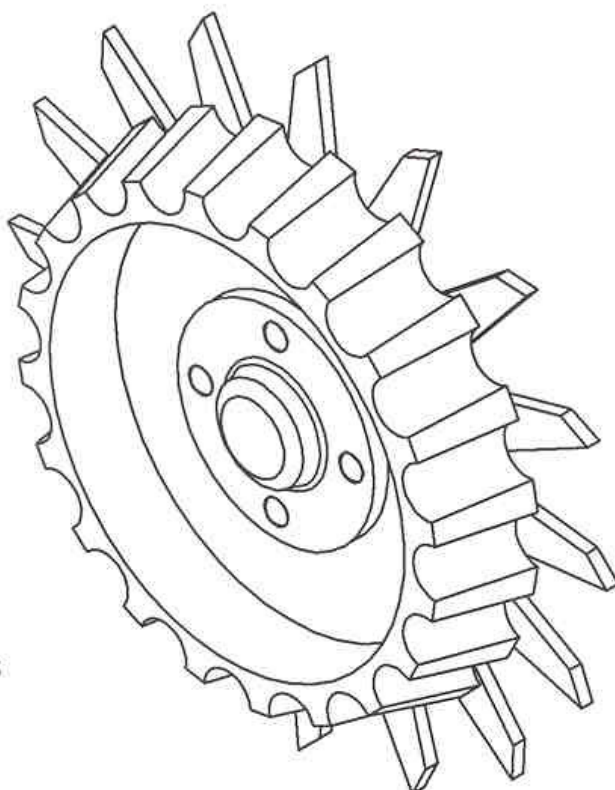

S280-3

2967-186 FLOATER WHEEL
L.H. ASSEMBLY SHOWN
(2) REQUIRED PER ROW

BOLT TORQUE

Mounting bolts and hardware

Before operating the Titan™ Residue Manager for the first time, check to be sure that all hardware is tight. Check all hardware again after approximately 50 hours of operation and at the beginning of each planting season.

All hardware used on the Titan™ Residue Manager is Grade 5 unless otherwise noted. Grade 5 cap screws are marked with three radial lines on the head. If hardware must be replaced, be sure to replace it with hardware of equal size, strength and thread type. Refer to the torque values chart when tightening hardware.



Important: Over tightening hardware can cause as much damage as when under tightening. Tightening hardware beyond the recommended range can reduce its shock load capacity.

The chart below is a guide for proper torque. Use it unless a specified torque is called out elsewhere in the manual.

Torque is the force you apply to the wrench handle or the cheater bar, times the length of the handle or bar.

Use a torque wrench whenever possible.

The following table shows torque in ft. lbs. for coarse thread hardware.

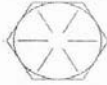
BOLT DIA. AND THREADS PER INCH	 GRADE 2	 OR  GRADE 5 A-325	 GRADE 8
1/4	6	10	14
5/16	12	20	30
3/8 - 16	25	35	50
7/16 - 14	35	55	80
1/2 - 13	55	85	125
9/16 - 12	75	125	175
5/8 - 11	105	170	235
3/4 - 10	185	305	425
7/8 - 9	170	445	690
1-8	260	670	1030
1 1/8 - 7	365	900	1460
1 1/4 - 7	515	1275	2060
1 3/8 - 6	675	1675	2700
1 1/2 - 6	900	2150	3500
1 3/4 - 5	1410	3500	5600

Lubricate all bearings and moving parts as assembled and make certain that they work freely.



WARNING: Never work around the toolbar/implement while in a raised position without using safety lockups.



CAUTION: The Titan™ Residue Manager attachments are very heavy. Pay extra attention to lifting techniques while handling and or maneuvering the opener during assembly. Failure to do so may lead to personal injury.

OPERATION



CAUTION: Where rocks are present the residue manager should be set in the “float” position, not locked down.

Adjust the residue manager to move crop residue aside and not move any soil. Adjustments to the residue manager may have to be made when changing field conditions and type and amount of residue. Use the handle for leverage when changing depth settings.

“FLOAT SETTINGS”

Install the adjustment pin below the combo arm.

To raise the wheels, lift the 2966-201 and move the adjustment pin up.

To lower the wheels, move the adjustment pin down.

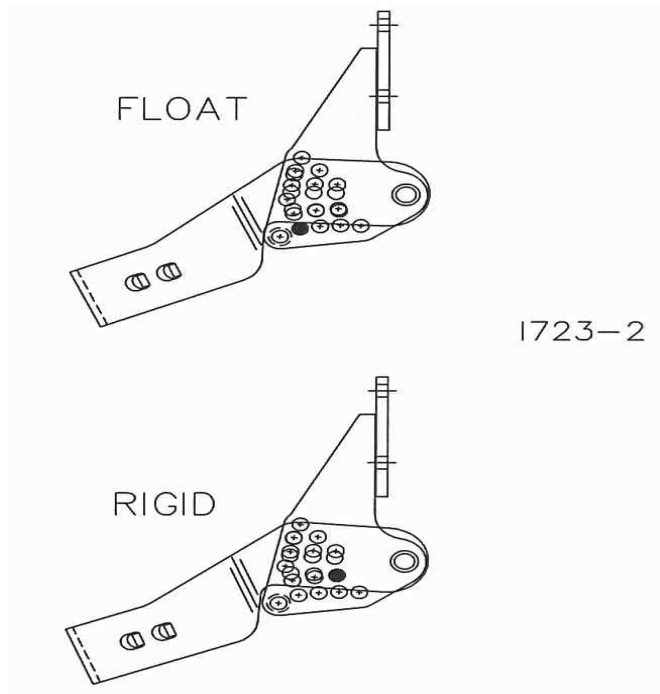

“RIGID SETTING”

Install the adjustment pin through the combo arm.

To raise the wheels, lift the 2966-201 combo arm to the desired position and insert the pin.

To lower the wheels, lower the combo arm to the desired position and insert the pin.

ROW CLEANER DO'S AND DON'TS

1. **DO NOT** move soil; Residue Managers are designed to move crop residue only.
2. **DO NOT** operate planter at slow speeds, ground speed affects how aggressive the spoke wheels are; operate at sufficient speed (4-6 mph) to maintain good residue flow.
3. **DO NOT** expect 100% of crop residue to be cleared, it is not necessary and would necessitate engaging the soil. The width of path cleared depends on ground conditions, depth setting and ground speed.
4. **DO** expect to see wheels occasionally quit turning, indicates ideal (shallow) setting which is not moving soil.
5. **DO** adjust toolbar frame height 20”-22” and drawbar to “level” correctly. Very important to ensure planter opener will follow ground contours properly.

OPERATION PRECAUTIONS

STOP

Read this before using the Yetter product.

- MACHINE OPERATION

IMPORTANT: failure to properly set the planter frame height and levelness can result in less than successful operation of the planter and the Yetter product and may result in damaged equipment. All operators should read and thoroughly understand the instructions given prior to using the Yetter product.

NOTE: **DO NOT** use this product if the planter is not adjusted properly!

Leveling the planter:

With the planter lowered to proper operating height (**Usually 20"-22"**). **Read the planter operator's manual for recommended setting**. Check to be sure the toolbar and row unit parallel arms are level fore and aft. **Re-check** when the planter is in the **field** and has been **fully loaded** with seed, fertilizer, granular chemicals, etc. Also, a field check with a bubble level on the frame should be made of the hitch height to ensure level operation front to back.

It is important for the planter to operate level laterally. Tire pressure must be maintained at pressures specified by the manufacturer.

Field and actual planting conditions change and will dictate planter frame heights. You must ensure that the row unit parallel arms are approximately parallel with the ground.

IMPORTANT: For proper operation of the planter attachments and row units, it is imperative that the planter toolbars and row unit parallel arms be level side-to-side and front-to-rear. The toolbar frame should operate at a 20"-22" height from the **planting surface**. Check the manufacturer's operator's manual for instructions on how to adjust the frame height and levelness.

PLANTER ADJUSTMENT

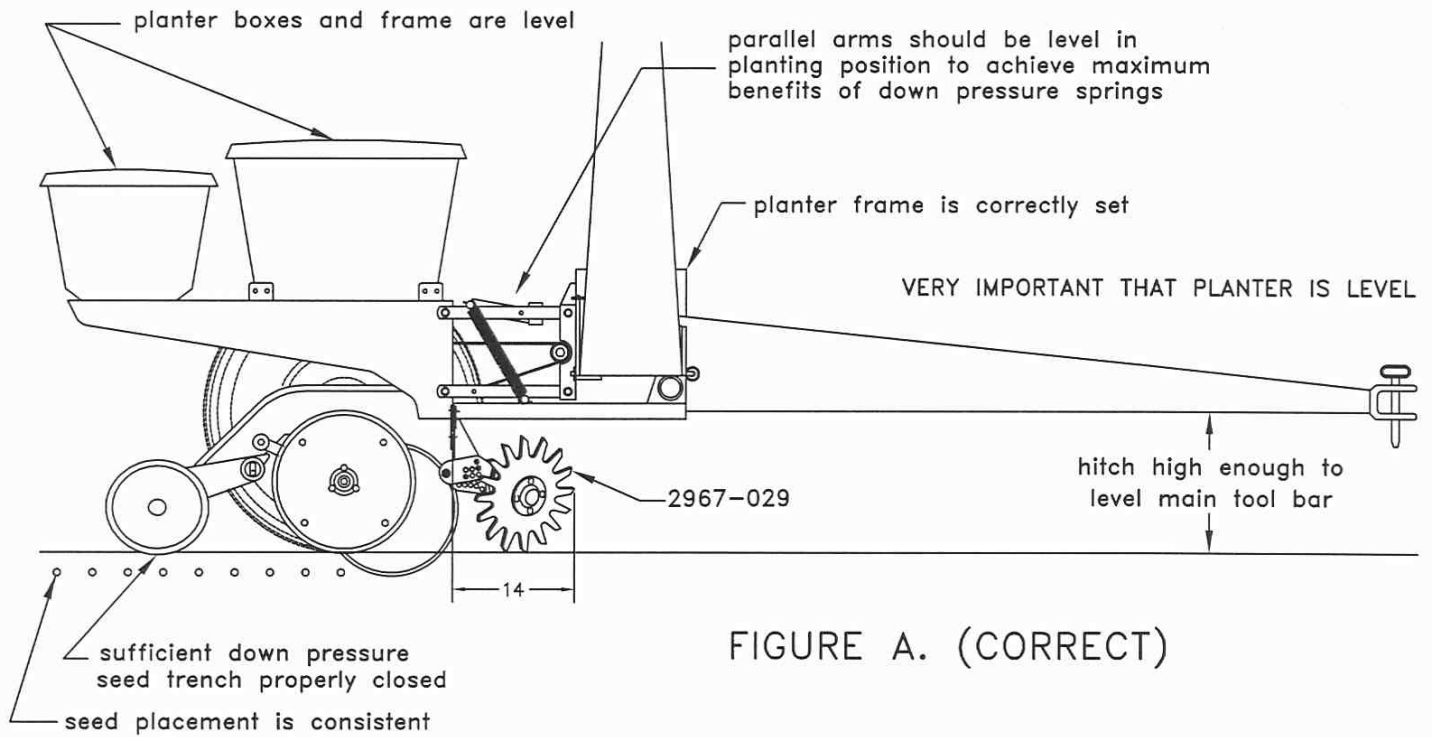

FIGURE A. (CORRECT)

1723-3

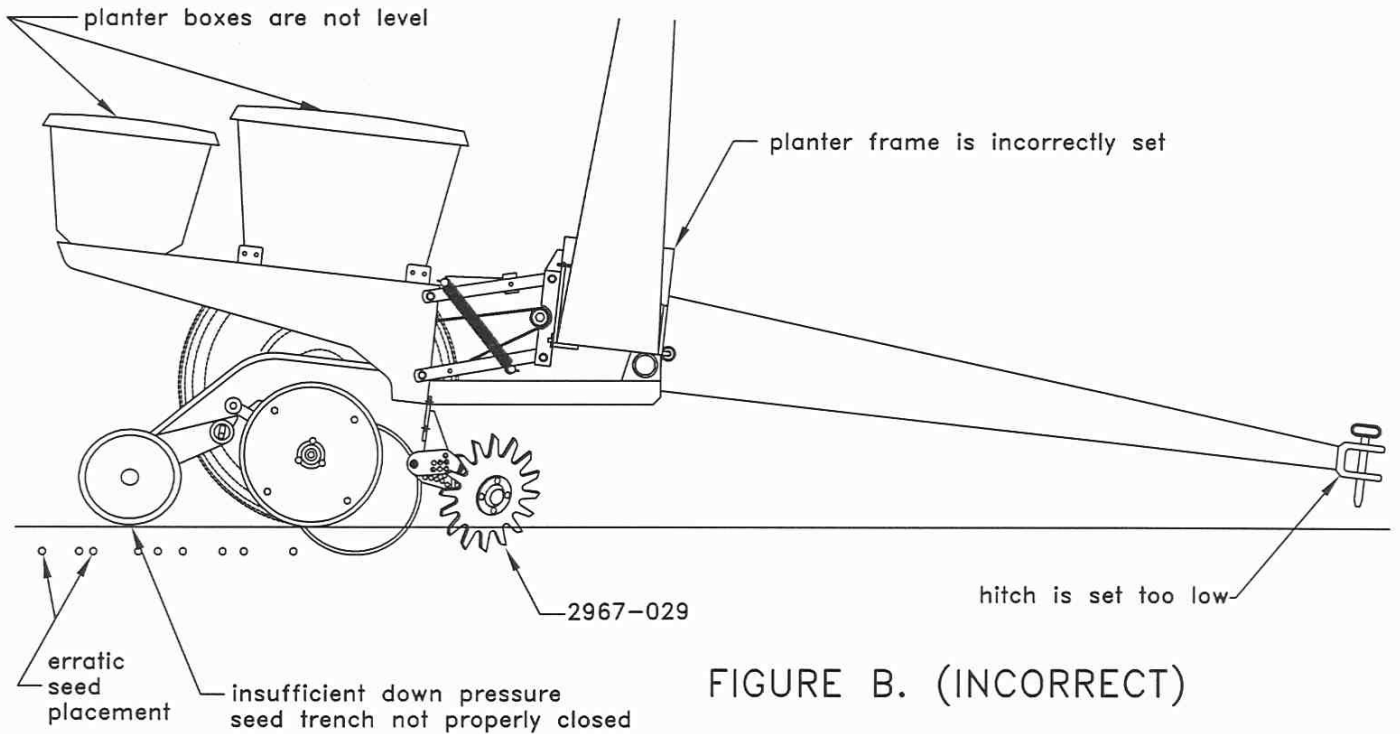
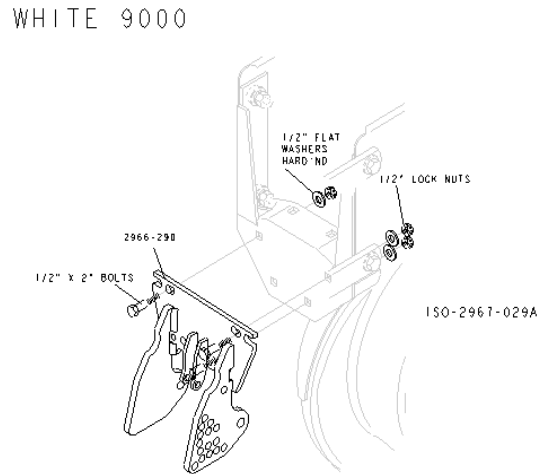
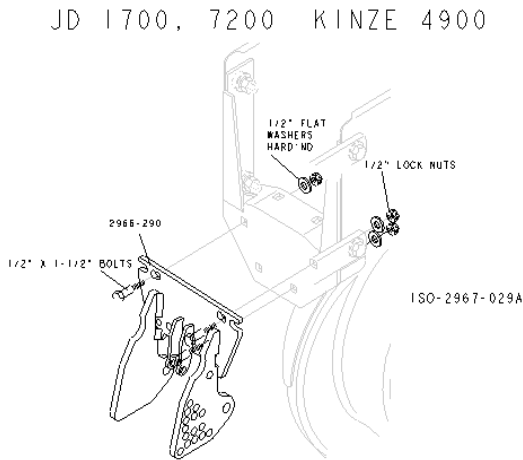
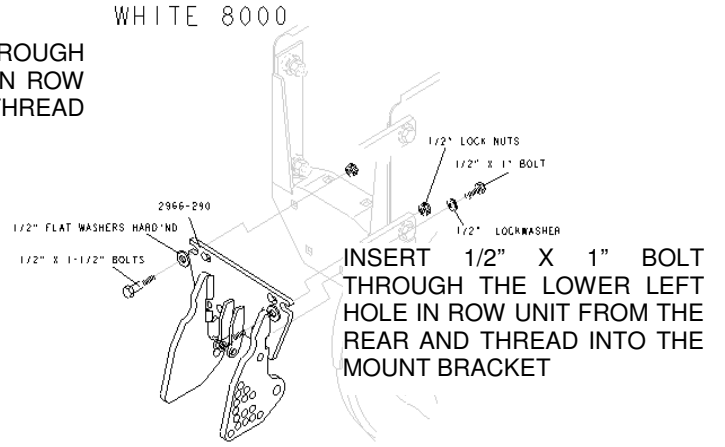
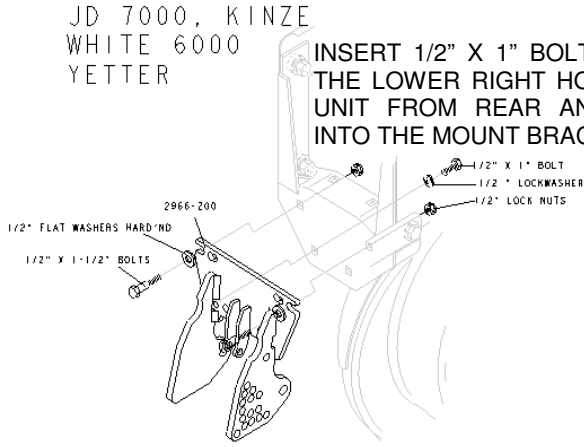

FIGURE B. (INCORRECT)

INSTALLATION INSTRUCTIONS

STEP 1. Attach the 2966-290 mount bracket to the planter unit using 3) 1/2" bolts and lock nuts.



STEP 1A. Attach the 2966-293 adapter to the CIH row unit using the 1/2" x 3-1/2" bolts and lock nuts then install the 2966-290 mount bracket to the adapter using the 1/2" x 1-1/2" carriage bolts and flanged lock nuts.

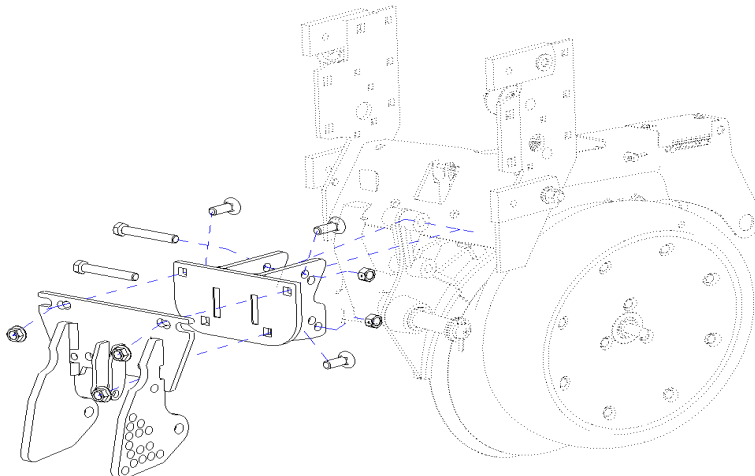

INSTALLATION INSTRUCTIONS

STEP 2. Install the arm up-stop using the 1/2" x 1-3/4" bolt 2967-622 spacer and lock nut. Attach the 2966-292 arm to the mount bracket on the left side using a 5/8" x 2" bolt, 6000-335 bushing, 2967-639 adjustment plate and lock nut. On the right side use a 5/8" x 2" bolt, 6000-335 bushing, flat washer and lock nut. Install the 1/2" x 2" bolt, 2967-622 spacer and lock nut on the left side to secure the adjustment plate and insert the 2984-326 pin in the adjustment holes and install the 2570-448 hairpin clip.

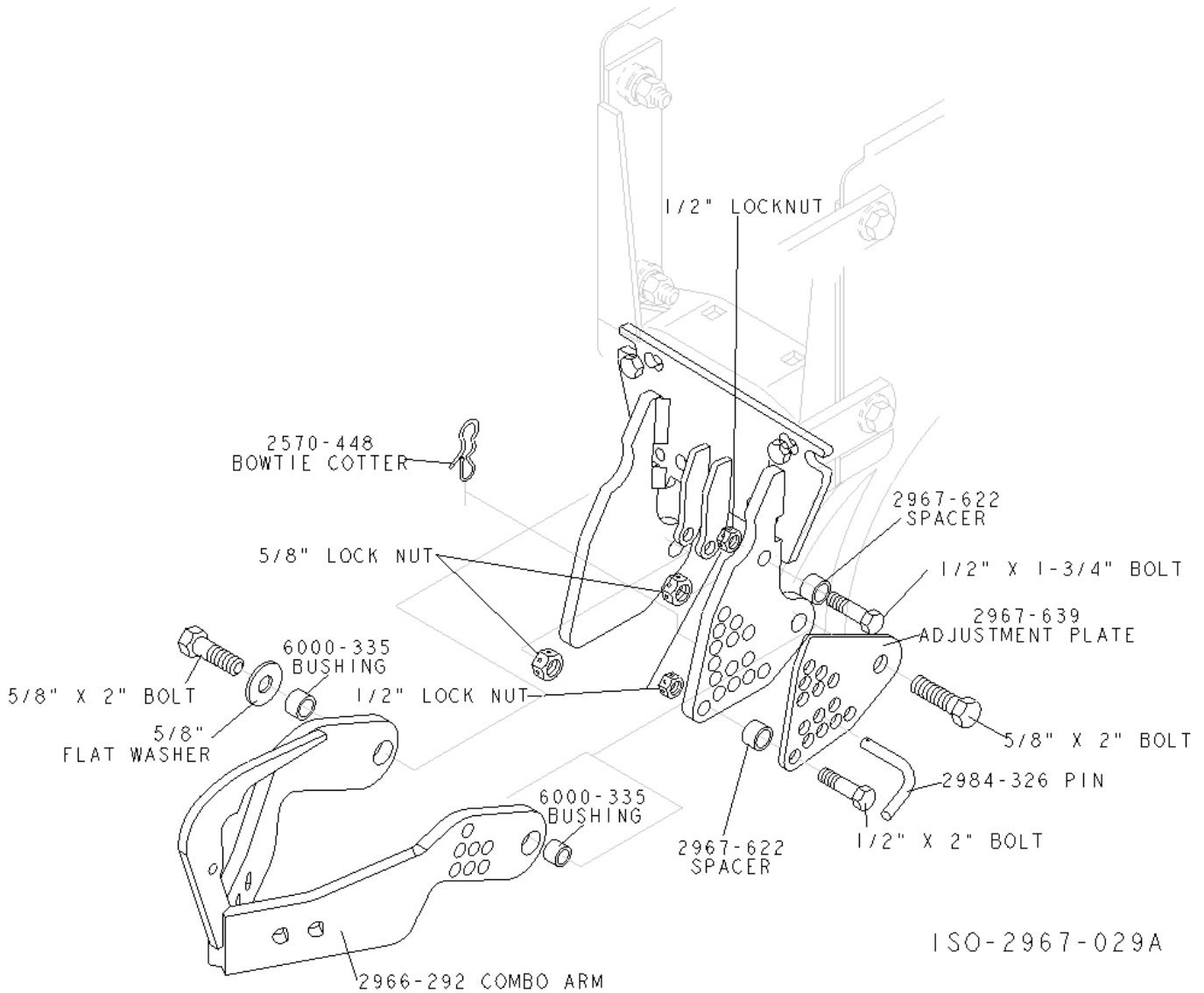

INSTALLATION INSTRUCTIONS

STEP 3. Fill the hub and bearing assembly with general-purpose grease.

STEP 4. Choose the hole in which to attach the R.M. wheel assemblies. Attach the R.M. wheel/hub assemblies to the combo arm using 5/8" lock washers and hex nuts. Adjust the bearing shield to top dead center, rotated slightly forward. Torque to 150 ft. lbs.

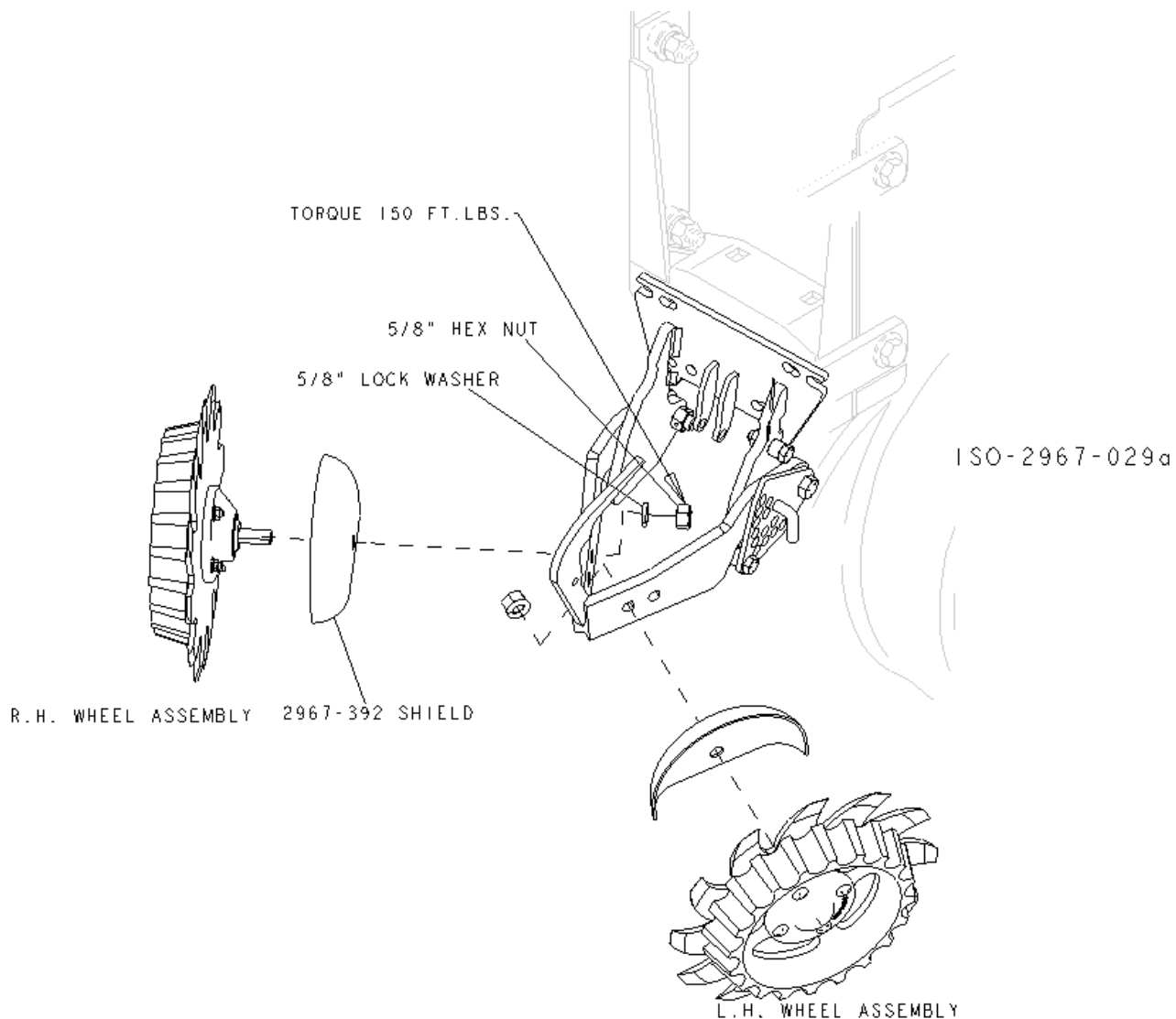

MAINTENANCE

Regularly inspect the residue manager for loose or worn parts. Repair and replace as needed.

BEARING ASSEMBLY AND LUBRICATION

Practice Safety

Understand and practice safe service procedures before doing work. Follow ALL the operating, maintenance and safety information in the equipment operator manual. Clear the area of bystanders, especially small children, when performing any maintenance or adjustments. Keep work area clean and dry. Use adequate lighting for the job. Use only tools, jacks and hoists of sufficient capacity for the job.

Never lubricate, service, or adjust machine while it is moving. Keep hands, feet, and clothing from power-driven moving and rotating parts. Disengage all power and operate controls to relieve pressure. Lower equipment to the ground and stop the engine. Remove the key.

Wait for all moving parts to stop before servicing, adjusting, repairing or unplugging.

Securely support any machine elements with blocks or safety stands that must be raised for service work.

Keep all parts in good condition and properly installed. Fix damaged equipment immediately. Replace worn or broken parts. Remove any buildup of grease, oil, or debris.

Make sure all guards are in place and properly secured when maintenance work is completed.

Assembly

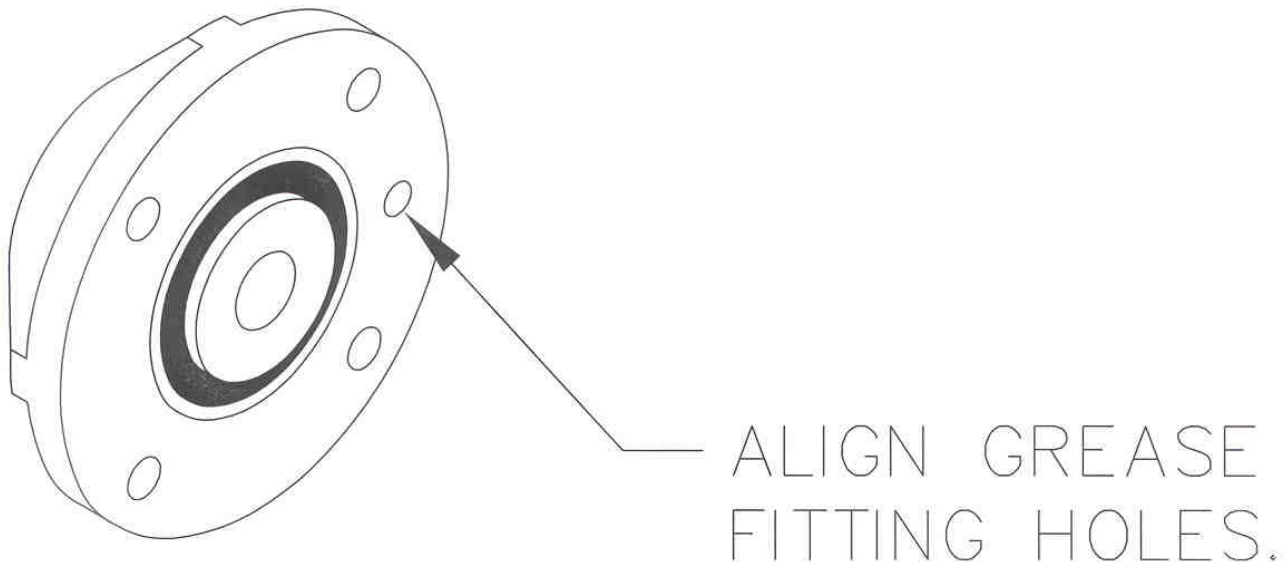

1190-1

MAINTENANCE

ALIGN THE HUB CAP GROOVE,
WITH THE WHEEL SLOT AND
GREASE FITTING

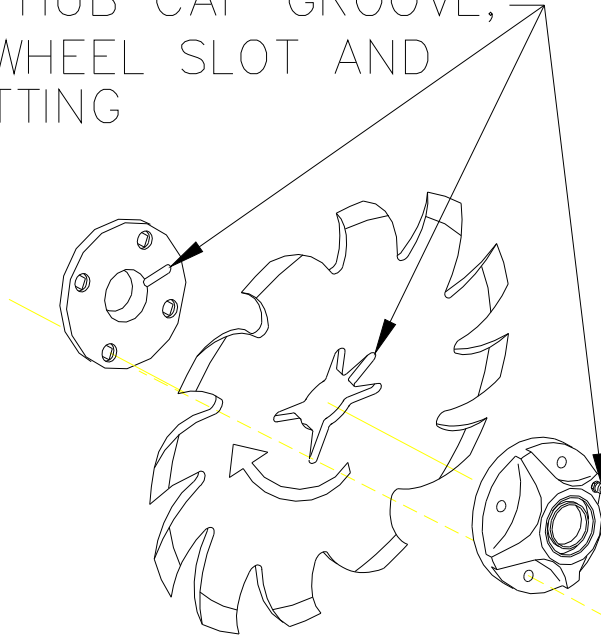

NOTE: Be certain to align the grease fitting with the slot in the wheel and the hubcap so that the grease can flow freely.

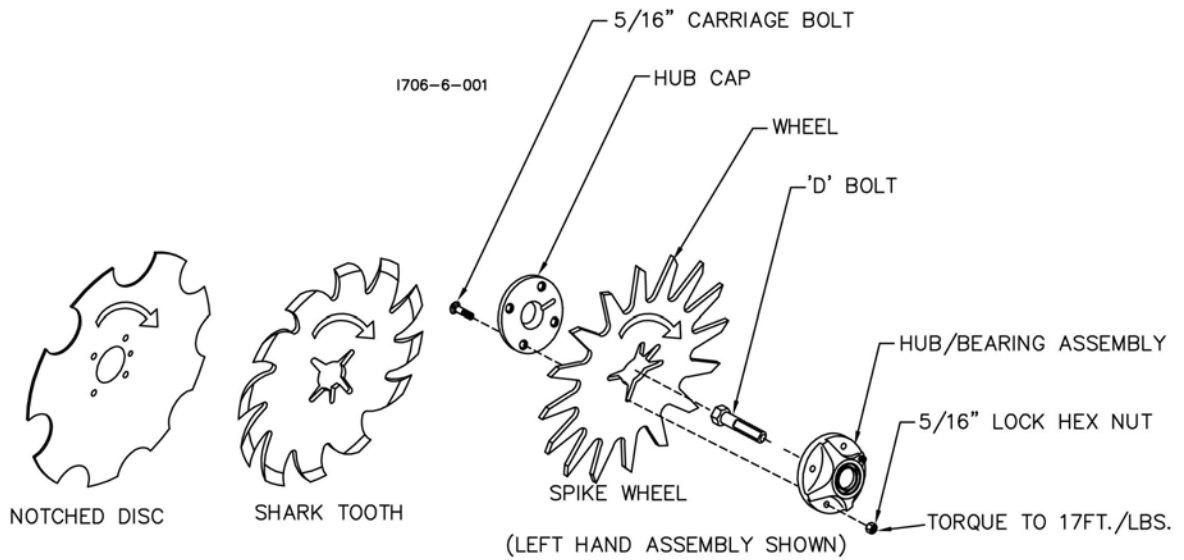

MAINTENANCE

Grease must fill this
Hubcap cavity.

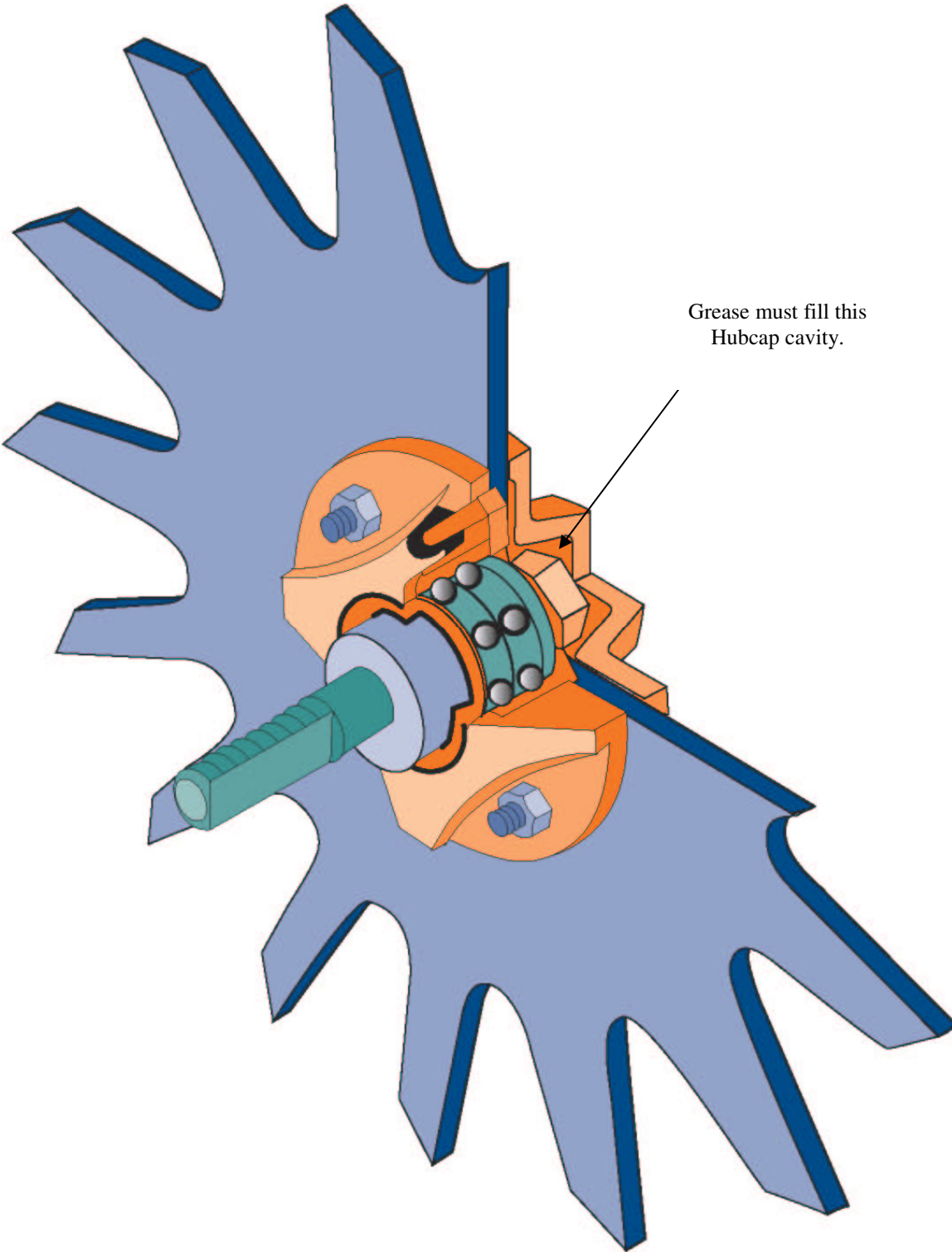

MAINTENANCE

Lubrication



CAUTION: To help prevent serious injury or death to you or others caused by unexpected movement, service machine on a level surface. Lower machine to ground or sufficiently lock or block raised machine before servicing. If machine is connected to tractor, engage parking brake and place transmission in "PARK", shut off engine and remove key. If machine is detached from tractor, block wheels and use shop stands to prevent movement.



CAUTION: Do not clean, lubricate, or adjust machine while in motion.

Use grease based on NLGI consistency numbers and the expected air temperature range during the service interval.

Use a **multi-purpose lithium, water resistant, moderate speed, and NLGI grade #2** grease.

Other greases may be used if they meet the following **NLGI Performance Classification: GC-LB**

IMPORTANT: Some types of grease thickener are not compatible with others. Consult your grease supplier before mixing different types of grease.

Alternative Lubricants

Conditions in certain geographical areas may require special lubricants and lubrication practices which do not appear in the operator's manual. If there are any questions, consult Yetter Manufacturing Co. to obtain latest information and recommendation.

PART #	DESCRIPTION	OUNCES OF GREASE
2967-404	13" TAPER TOOTH R.M. WHEEL	1.12 OZ
2967-602	13" SHARK TOOTH R.M. WHEEL	1.12 OZ
2967-186	FLOATER WHEEL KIT W/R.M. WHEEL	2.08 OZ
2967-596	HEAVY DUTY OR BEVEL R.M. WHEEL W/ FLOATER WHEEL KIT	2.40 OZ

Storing Lubricants

Your machine can operate at top efficiency only if clean lubricants are used.

Use clean containers to handle all lubricants.

Store them in an area protected from dust, moisture and other contaminants.

MAINTENANCE

Lubrication Symbols

 Lubricate with grease at hourly interval indicated on symbol.

Lubrication Intervals

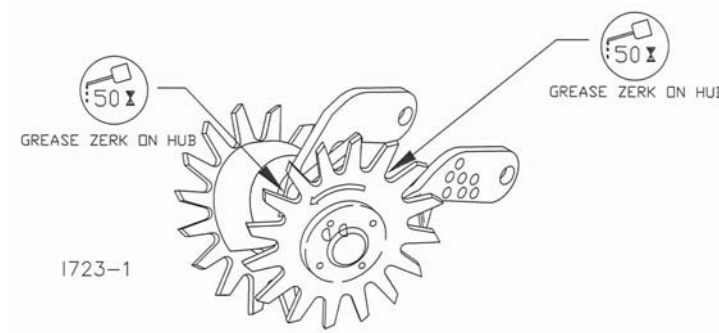

IMPORTANT: The recommended service intervals are based on normal conditions; severe or unusual conditions may require more frequent lubrication.

Perform each lubrication and service procedure at the beginning and end of each season.

Clean grease fittings before using grease gun, to avoid injecting dirt and grit into the bearing. Replace any lost or broken fittings immediately. If a fitting fails to take grease, remove and clean thoroughly, replace fitting if necessary. Also check for failure of adjoining parts.

BEARING REPLACEMENT INSTALLATION

1. When assembling the spoke wheels, bearing assembly and hubcap, be sure to align the grease transfer hole in the spoke wheel with the groove in the hubcap and hole in the hub to allow grease passage.
2. Assemble the wheels, hubs and caps.
3. Grease the wheel/hub/bearing assembly.

MAINTENANCE

Storing the Equipment

Store the machine in an area away from human activity

Store machine in RAISED position.

Install service locks on all wheel cylinders.

At the end of the season, the machine should be thoroughly inspected and prepared for storage. Repair or replace any worn or damaged components to prevent down time at the start of the next season. Store machine under cover with all parts in operating condition.

- Clean machine thoroughly to remove all dirt, debris and crop residue, which would hold moisture and cause rusting.
- Inspect machine for worn or broken parts. See your Yetter Farm Equipment dealer during the off-season so that parts or service can be acquired when machine is not needed in the field.
- Lubricate bearings as outlined in the Lubrication section
- Paint all parts which are chipped or worn and require repainting.
- Store machine in a clean, dry place with the planting unit out of the sun.
- If the machine cannot be stored inside, cover with a waterproof tarpaulin and tie securely in place.
- Do not allow children to play on or around the machine

PARTS IDENTIFICATION 2967-029

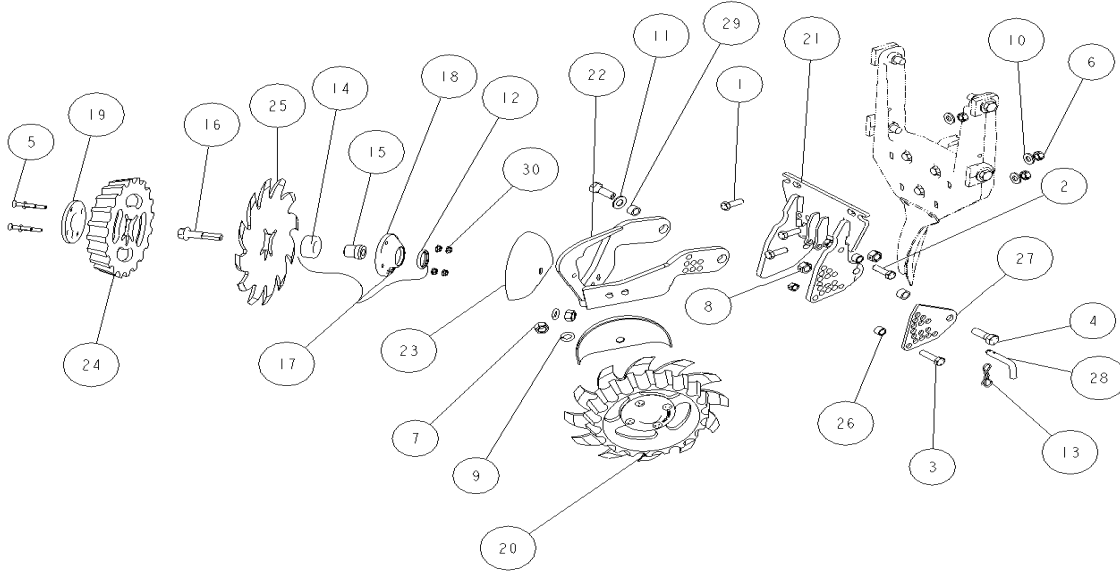

ITEM	PART #	DESCRIPTION	QTY
1	2502-294	1/2 -13 X 1-1/2 HHCS GRADE 5	3
	2502-351	1/2 -13 X 2 HHCS GRADE 5 (WHITE 9000)	3
2	2502-317	1/2 -13 X 1-3/4 HHCS GRADE 5	1
3	2502-351	1/2 -13 X 2 HHCS GRADE 5	1
4	2502-391	5/8 -11 X 2 HHCS GRADE 5	2
5	2505-209	5/16 -18 X 1-3/4 CARRIAGE BOLT GRADE 5 (FLOATER)	8
	2505-207	5/16 -18 X 1-1/4 CARRIAGE BOLT GRADE 5 (SHARK)	8
	2505-208	5/16 -18 X 1-1/2 CARRIAGE BOLT GRADE 5 (BEVELED)	8
6	2520-357	1/2 -13 LOCK HEX NUT	5
7	2520-452	5/8 -11 HEX NUT	2
8	2520-459	5/8 -11 LOCK HEX NUT	2
9	2525-451	5/8 LOCK WASHER	2
10	2526-355	1/2 FLAT WASHER HARDENED	3
11	2526-453	5/8 SAE FLAT WASHER	1
12	2550-069	SEAL	2
13	2570-448	HAIRPIN COTTER	1
14	2570-594	BEARING	2
15	2570-715	INSERT	2
16	2570-740	D-BOLT 5/8 -11 X 2.812 GRADE 8	2
17	2965-128	HUB AND BEARING ASSEMBLY	2
18	2965-351	HUB	2
19	2965-352	CAP	2
20	2966-141-ST-FW	SHARK WHEEL ASSEMBLY LH FLOATER (SHOWN)	1
	2966-141-ST-FW	SHARK WHEEL ASSEMBLY RH FLOATER	1
21	2966-290	MOUNT BRACKET	1
22	2966-292	ARM WIDE	1
23	2967-392	SHIELD	2
24	2967-555	FLOATER WHEEL (OPTION)	2
25	2967-602	13" SHARK WHEEL (SHOWN)	2
	2967-404	13" TAPER TOOTH (OPTION)	2
	6200-350	13" BEVELED WHEEL LH (OPTION)	1
	6200-351	13" BEVELED WHEEL RH (OPTION)	1
26	2967-622	9/16" SPACER	2
27	2967-639	ADJUSTMENT PLATE	1
28	2984-326	PIN	1
29	6000-335	9/16" BUSHING	2
30	N10213	5/16 -18 SERRATED FLANGE HEX NUT	8

PARTS IDENTIFICATION

2967-097

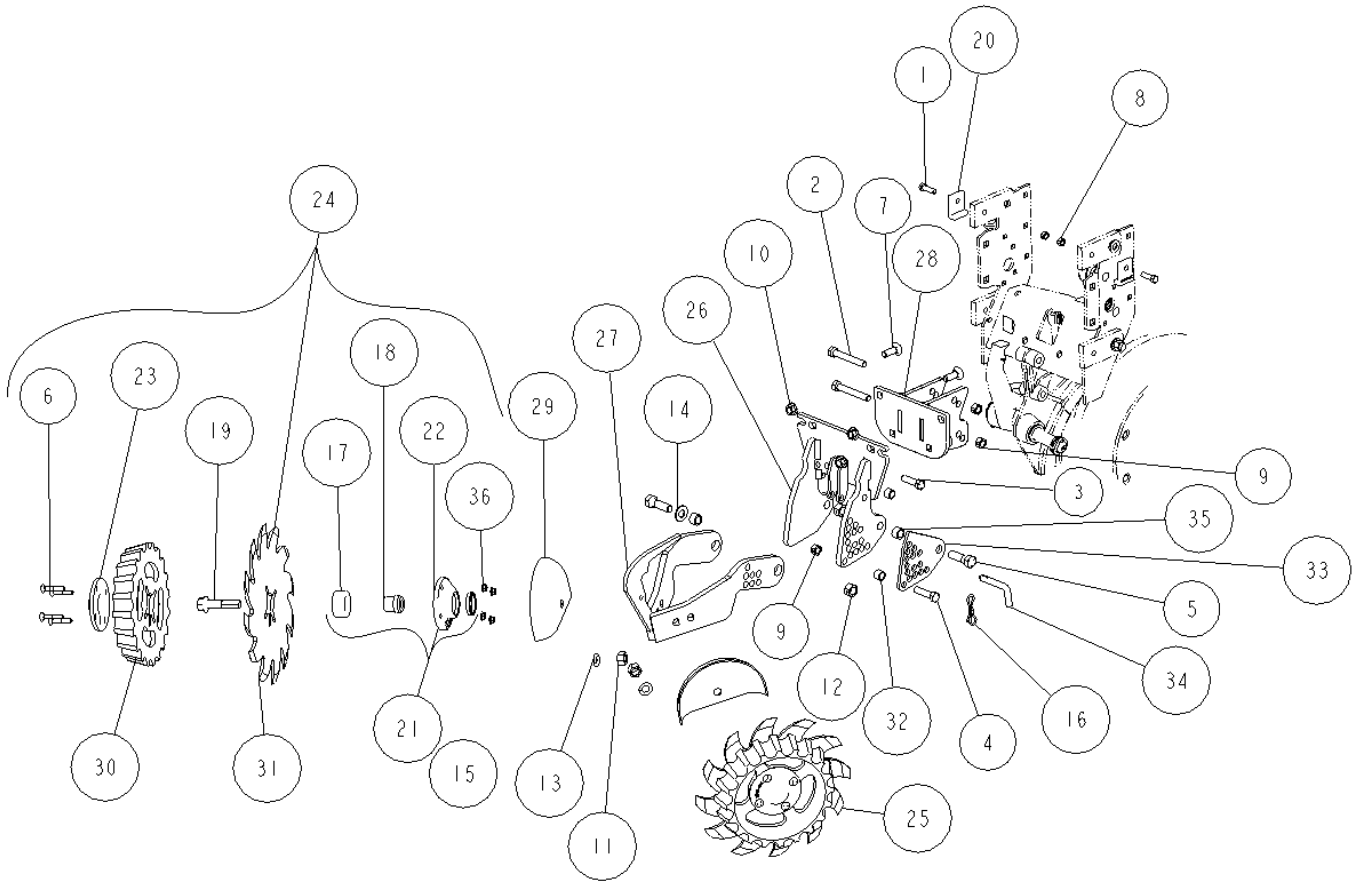

ITEM	PART #	DESCRIPTION	QTY
1	2502-244	3/8 -16 X 1-1/4 HHCS GRADE 5	2
2	2502-316	1/2 -13 X 3-1/2 HHCS GRADE 5	2
3	2502-317	1/2 -13 X 1-3/4 HHCS GRADE 5	1
4	2502-351	1/2 -13 X 2 HHCS GRADE 5	1
5	2502-391	5/8 -11 X 2 HHCS GRADE 5	2
6	2505-209	5/16-18 X 1-3/4 CARRIAGE BOLT GRADE5(FLOATER)	8
	2505-207	5/16-18 X 1-1/4 CARRIAGE BOLT GRADE 5(SHARK)	8
	2505-208	5/16-18 X 1-1/2 CARRIAGE BOLT GRADE5(BEVEL)	8
7	2505-339	1/2 -13 X 1-1/2 CARRIAGE BOLT GRADE 5	3
8	2520-255	3/8 -16 LOCK HEX NUT	2
9	2520-357	1/2 -13 LOCK HEX NUT	4
10	2520-361	1/2 -13 FLANGE HEX NUT	3
11	2520-452	5/8 -11 HEX NUT	2
12	2520-459	5/8 -11 LOCK HEX NUT	2
13	2525-451	5/8 LOCK WASHER	2
14	2526-453	5/8 SAE FLAT WASHER	1
15	2550-069	SEAL	2
16	2570-448	HAIR PIN COTTER	1
17	2570-594	BEARING	2
18	2570-715	INSERT	2
19	2570-740	D-BOLT FLANGED 5/8 -11 X 2.812 GRADE 8	2

ITEM	PART #	DESCRIPTION	QTY
20	2960-223	UP-STOP	
21	2965-128	BEARING HUB ASSEMBLY	2
22	2965-351	HUB	2
23	2965-352	CAP	2
24	2966-140-ST-FW	SHARK WHEEL ASSEMBLY RH	1
25	2966-141-ST-FW	SHARK WHEEL ASSEMBLY LH	1
26	2966-290	MOUNT BRACKET	1
27	2966-292	ARM	1
28	2966-293	ADAPTER CIH	1
29	2967-392	SHIELD	2
30	2967-555	FLOATER WHEEL (OPTION)	2
31	2967-602	13" SHARK WHEEL (SHOWN)	2
	2967-404	13" TAPER TOOTH (OPTION)	2
	6200-350	13" BEVELED WHEEL LH (OPTION)	1
	6200-351	13" BEVELED WHEEL RH (OPTION)	1
32	2967-622	9/16" SPACER	2
33	2967-639	ADJUSTMENT PLATE	1
34	2984-326	PIN	1
35	6000-335	9/16" BUSHING	2
36	N10213	5/16 -18 SERRATED FLANGE HEX NUT	8

NOTES:

Our name Is getting known

Just a few years ago, Yetter products were sold primarily to the Midwest only. Then we embarked on a program of expansion and moved into the East, the South, the West and now north into Canada. We're even getting orders from as far away as Australia and Africa.

So, when you buy Yetter products . . .you're buying a name that's recognized. A name that's known and respected. A name that's become a part of American agriculture and has become synonymous with quality and satisfaction in the field of conservation tillage.

Thank you.

YETTER MANUFACTURING CO.

Colchester, IL 62326-0358 • 309/776-4111

Toll Free 800/447-5777

Fax 309/776-3222

Website: WWW.YETTERCO.COM

E-MAIL: INFO@YETTERCO.COM