



6200-001/ 6200-003

CAST SPIKE CLOSE WHEEL KIT

2565-734_REV_E 09/2014

PARTS IDENTIFICATION

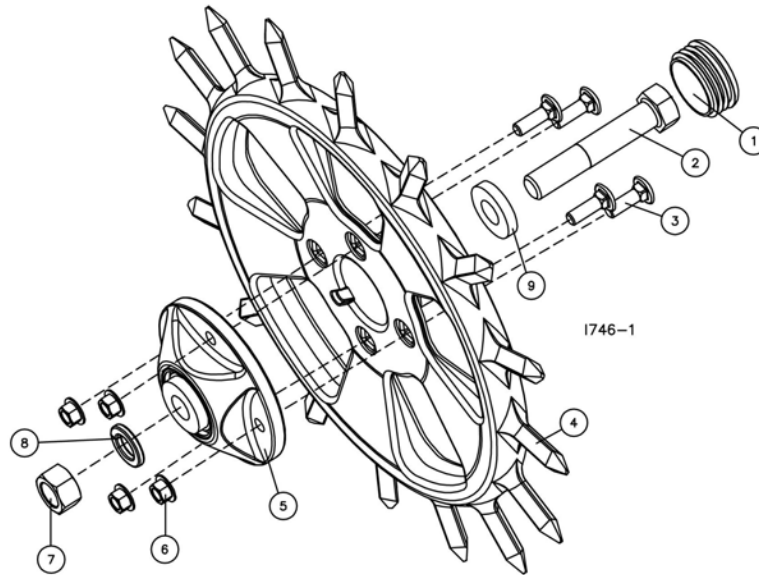

6200-001 – CAST SPIKE CLOSE WHEEL KIT – (KINZE)

DET	QTY	PART NO.	DESCRIPTION
1	2	2515-726	POLY HUB CAP, NIAGRA #RT14
2	2	2502-325	5/8-11 X 3 HHCS GR 5 ZYD.
3	8	2505-206	5/16-18 X 1 CAR BLT GR 5 ZYD.
4	2	6200-355	CAST SPIKE WHEEL, PAINTED
5	2	2965-128	HUB AND BEARING ASSEMBLY
		2550-069	SEAL
		2570-594	BEARING
		2570-715	BEARING INSERT
		2965-351	HUB
		2533-110	1/4-28 ZERK STRAIGHT SELF-TAP
6	8	N10213	5/16-18 HEX FLANGE SERRATED NUT
7	2	2520-452	5/8-11 HEX NUT ZYD.
8	2	2525-451	5/8-11 MED LOCK WASHER ZYD.
9	2	2527-530	1.50D X 21/32ID 3/16TK MA BU

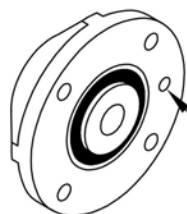

ALIGN GREASE
FITTING HOLES.

PARTS IDENTIFICATION

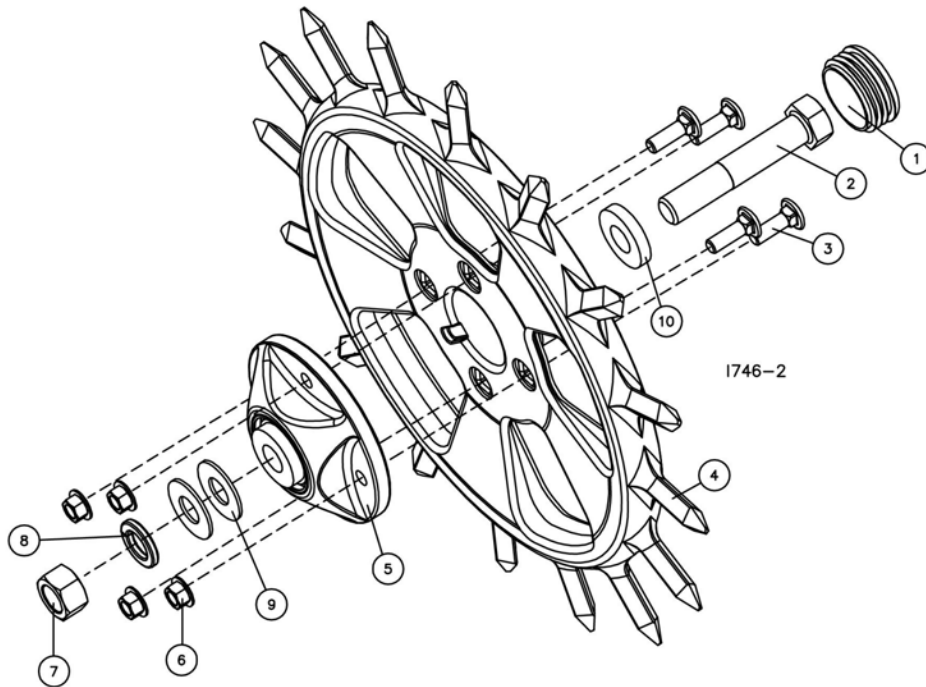

6200-001 - CAST SPIKE CLOSE WHEEL KIT - (WHITE)

DET	QTY	PART NO.	DESCRIPTION
1	2	2515-726	POLY HUB CAP, NIAGRA #RT14
2	2	2502-324	5/8-11 X 3-1/2 HHCS GR 5 ZYD.
3	8	2505-206	5/16-18 X 1 CAR BLT GR 5 ZYD.
4	2	6200-355	CAST SPIKE WHEEL, PAINTED
5	2	2965-128	HUB AND BEARING ASSEMBLY
		2550-069	SEAL
		2570-594	BEARING
		2570-715	BEARING INSERT
		2965-351	HUB
		2533-110	1/4-28 ZERK STRAIGHT SELF-TAP
6	8	N10213	5/16-18 HEX FLANGE SERRATED NUT
7	2	2520-452	5/8-11 HEX NUT ZYD.
8	2	2525-451	5/8-11 MED LOCK WASHER ZYD.
9	4	2526-455	WASHER 21/32" X 1 1/4" X 1/4"
10	2	2527-530	1.50D X 21/32ID 3/16TK MA BU

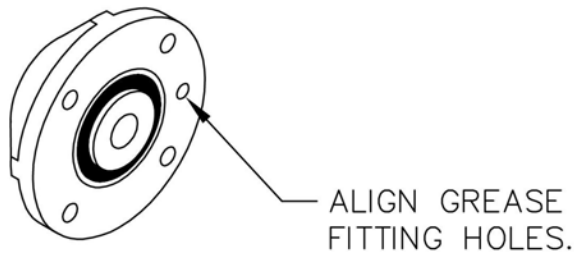

PARTS IDENTIFICATION

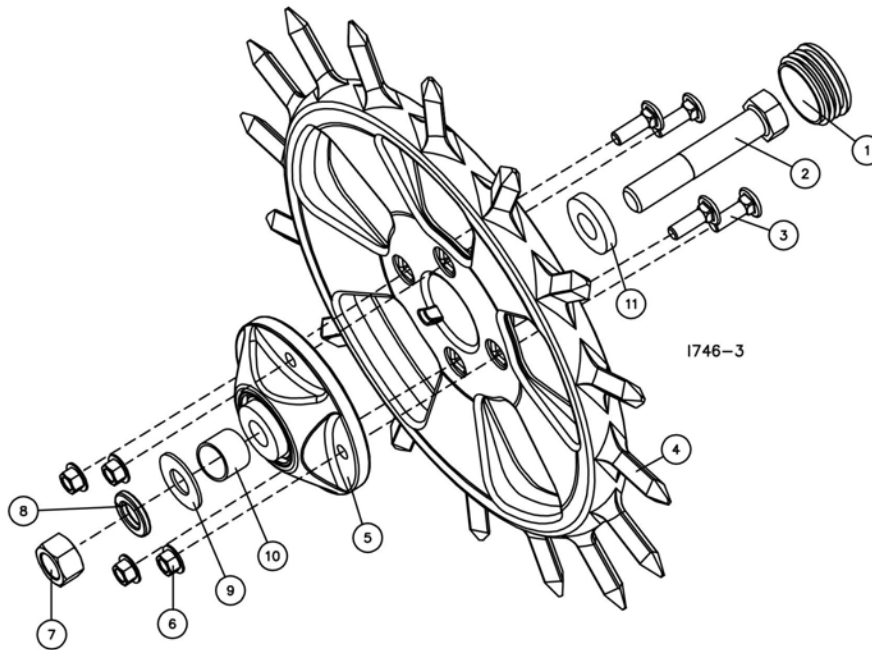

6200-001 - CAST SPIKE CLOSE WHEEL KIT - (JOHN DEERE)

DET	QTY	PART NO.	DESCRIPTION
1	2	2515-726	POLY HUB CAP, NIAGRA #RT14
2	2	2502-324	5/8-11 X 3-1/2 HHCS GR 5 ZYD.
3	8	2505-206	5/16-18 X 1 CAR BLT GR 5 ZYD.
4	2	6200-355	CAST SPIKE WHEEL, PAINTED
5	2	2965-128	HUB AND BEARING ASSEMBLY
		2550-069	SEAL
		2570-594	BEARING
		2570-715	BEARING INSERT
		2965-351	HUB
		2533-110	1/4-28 ZERK STRAIGHT SELF-TAP
6	8	N10213	5/16-18 HEX FLANGE SERRATED NUT
7	2	2520-452	5/8-11 HEX NUT ZYD.
8	2	2525-451	5/8-11 MED LOCK WASHER ZYD.
9	2	2526-455	WASHER 21/32" X 1 1/4" X 1/4"
10	2	6000-335	9/16" BUSHING
11	2	2527-530	1.50D X 21/32ID 3/16TK MA BU

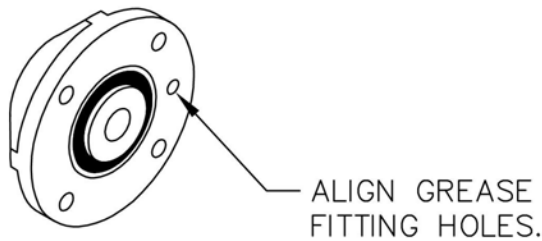

PARTS IDENTIFICATION

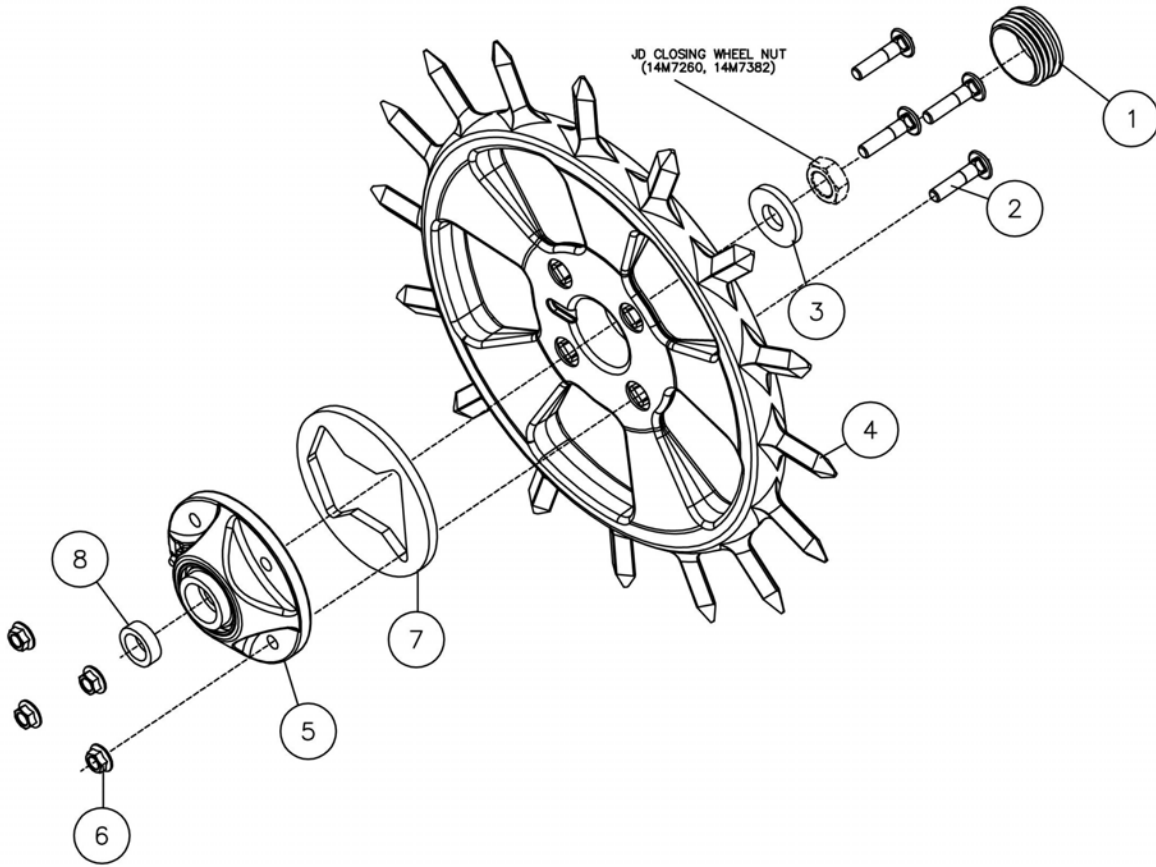

6200-003 SPIKE CLOSING WHEEL FOR JD 7200

DET	QTY	PART NO.	DESCRIPTION
1	2	2515-726	POLY HUB CAP, NIAGRA #RT14
2	8	2505-207	5/16-18 X 1-1/4 CAR BLT GR 5 ZYD.
3	2	2527-530	1.50D X 21/32ID 3/16TK MA BU
4	2	6200-355	CAST SPIKE WHEEL, PAINTED
5	2	6200-358	BEARING HUB, 7200 CLOSING WHEEL
		2550-069	SEAL
		2570-594	BEARING
		2965-351	HUB
		6200-359	CLOSE WHEEL INSERT / 7200
6	8	N10213	5/16-18 HEX FLANGE SERRATED NUT
7	2	6200-360	SHIM SPACER
8	2	6200-361	SPACER

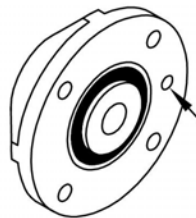

1769-2
UPDATED 05/30/13

ALIGN GREASE
FITTING HOLES.

PARTS IDENTIFICATION

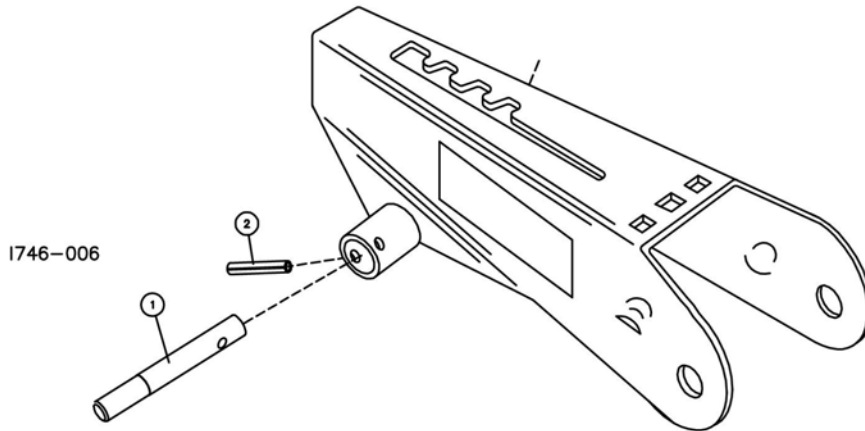

6200-143 - CLOSE WHEEL STUD KIT

DET	QTY	PART NO.	DESCRIPTION
1	2	6200-356	WHEEL SPINDLE
2	2	2530-155	1/4 X 1-1/4 ROLL PIN ZP

NOTE: USE THE NUT AND LOCKWASHER FROM THE 6200-001 CAST SPIKE KIT

UPDATED 12/17/12

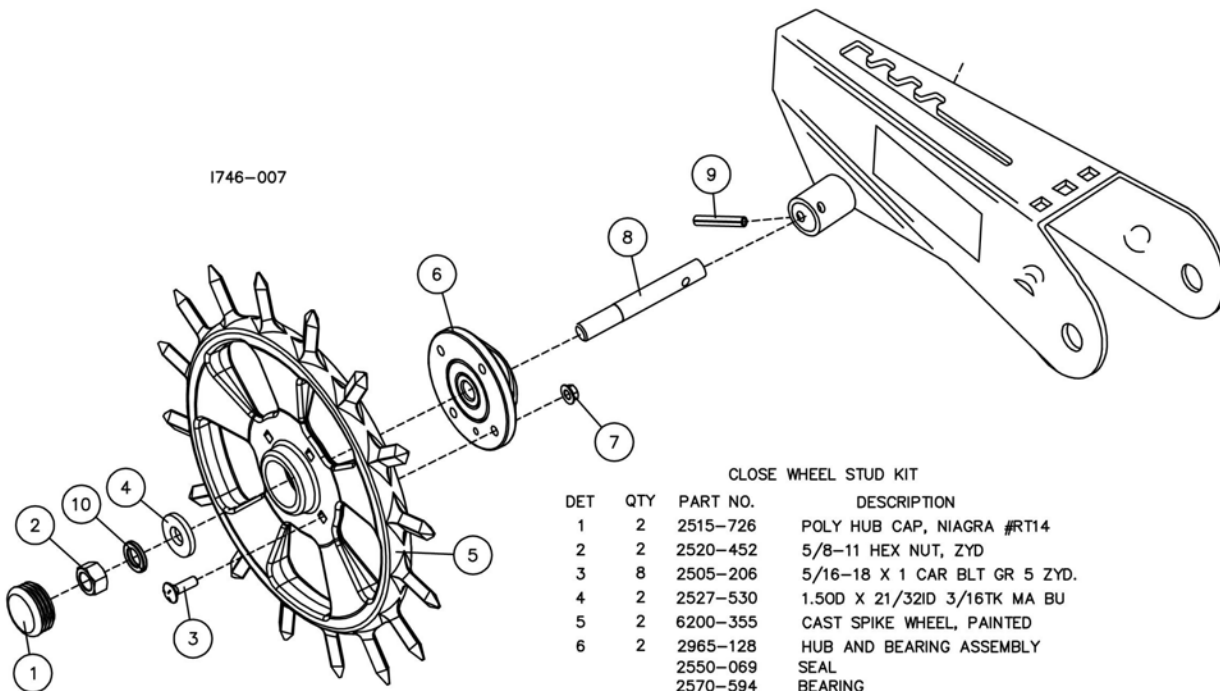

CLOSE WHEEL STUD KIT

DET	QTY	PART NO.	DESCRIPTION
1	2	2515-726	POLY HUB CAP, NIAGRA #RT14
2	2	2520-452	5/8-11 HEX NUT, ZYD
3	8	2505-206	5/16-18 X 1 CAR BLT GR 5 ZYD.
4	2	2527-530	1.50D X 21/32ID 3/16TK MA BU
5	2	6200-355	CAST SPIKE WHEEL, PAINTED
6	2	2965-128	HUB AND BEARING ASSEMBLY
		2550-069	SEAL
		2570-594	BEARING
		2570-715	BEARING INSERT
		2965-351	HUB
		2533-110	1/4-28 ZERK STRAIGHT SELF-TAP
7	8	N10213	5/16-18 HEX FLANGE SERRATED NUT
8	2	6200-356	WHEEL SPINDLE
9	2	2530-155	1/4 X 1-1/4 ROLL PIN ZP
10	2	2525-451	5/8 MED LOCKWASHER ZP

UPDATED 04/11/13

ASSEMBLY INSTRUCTIONS

STEP 1. Assemble the close wheels to the hub/bearing using the 5/16" x 1" carriage bolts and 5/16" flange lock nuts.

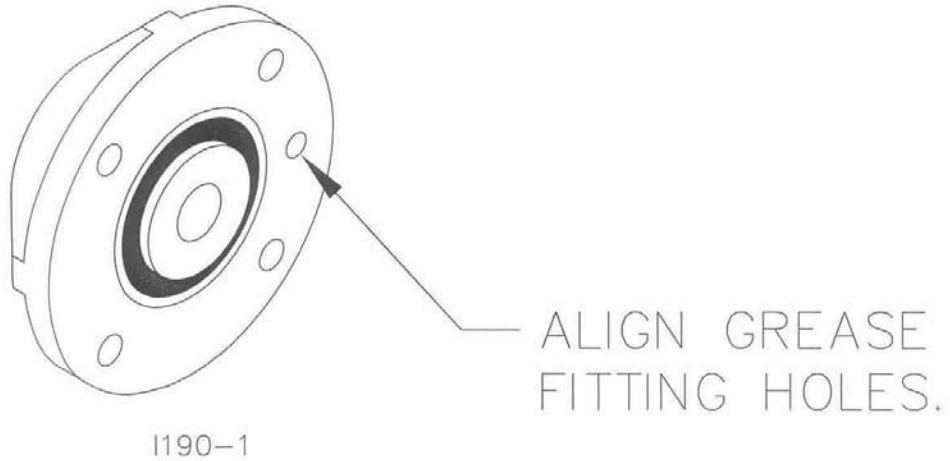

STEP 2. Attach the wheel assemblies to the close wheel arm.

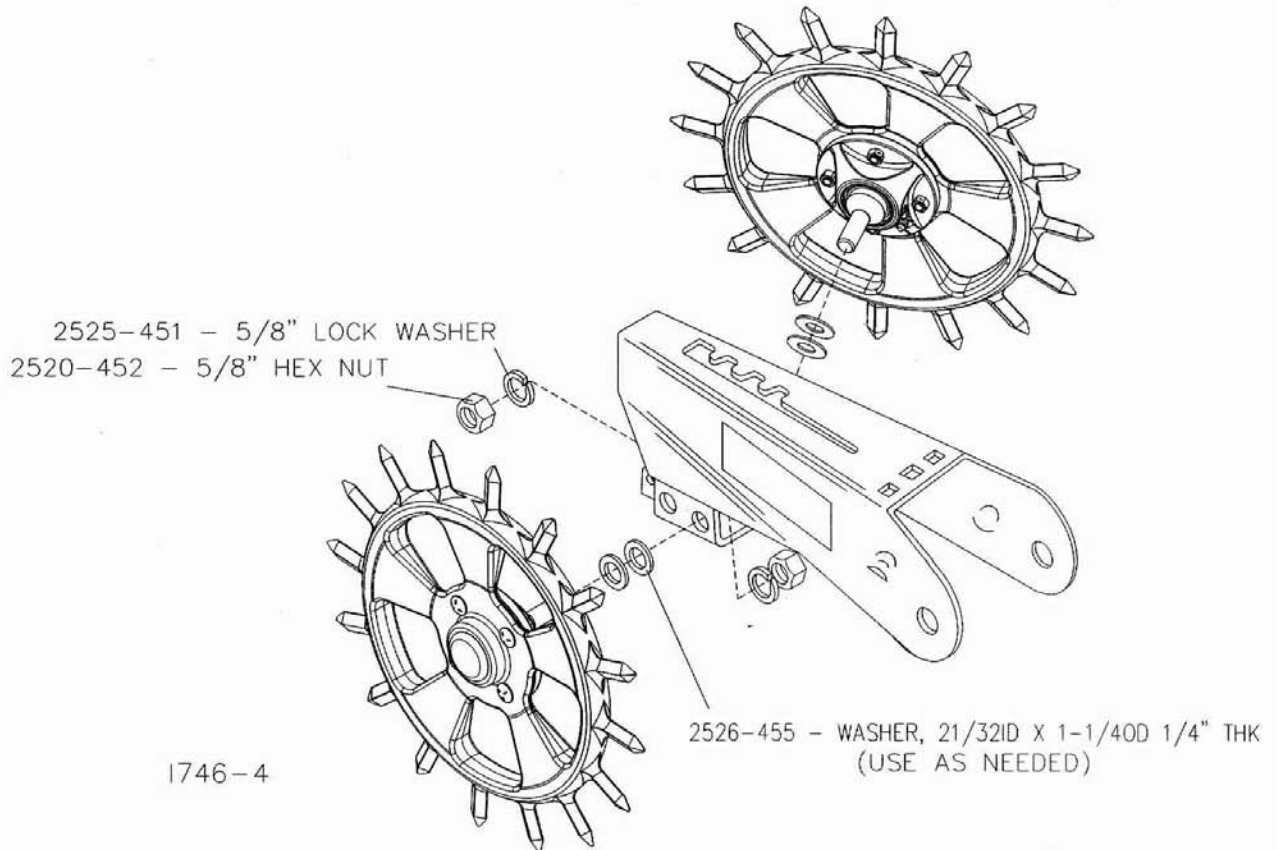

ASSEMBLY INSTRUCTIONS

STEP 3. Install the wheels, using the spacers as needed, so that the distance at the bottom of the wheels is approximately 2-1/4"-2-1/2".

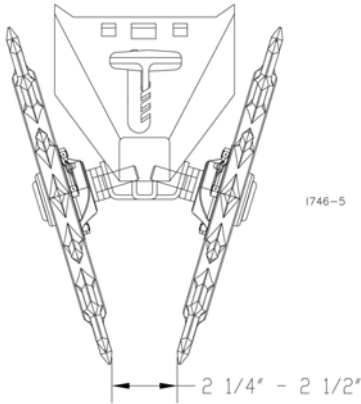

Installation Tip: When using one spike and one rubber wheel: Install two spike wheels on a row unit to determine the correct amount of spacers for proper distance of the spike wheel from the seed, reinstall the rubber wheel and use the same amount of spacers on the spike wheel for the other row units.

STEP 4. Adjust the close wheel spring tension as necessary. If the seed trench is not being closed properly, increase the closing wheel spring pressure. Closing wheels must not sink into the soil too deeply, the seed placement could be adversely affected, especially when planting shallow. If the closing wheels are applying too much pressure and the seed is being moved by the closing wheels, decrease closing wheel pressure. Light soils usually require less down pressure; heavy soils more down pressure.

6200-002, SCRAPER KIT FOR 6200-001

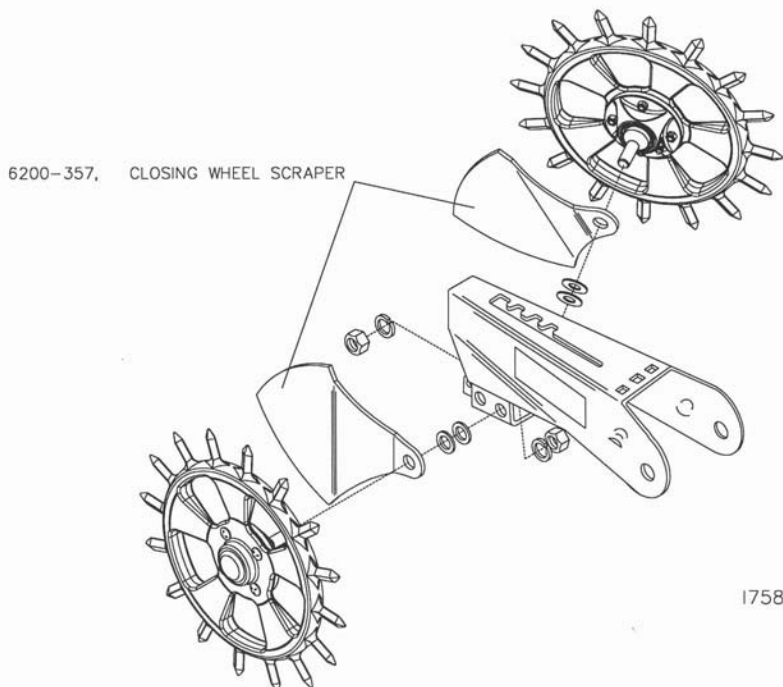

6200-002

CLOSING WHEEL SCRAPER SIDE VIEW

L629-002

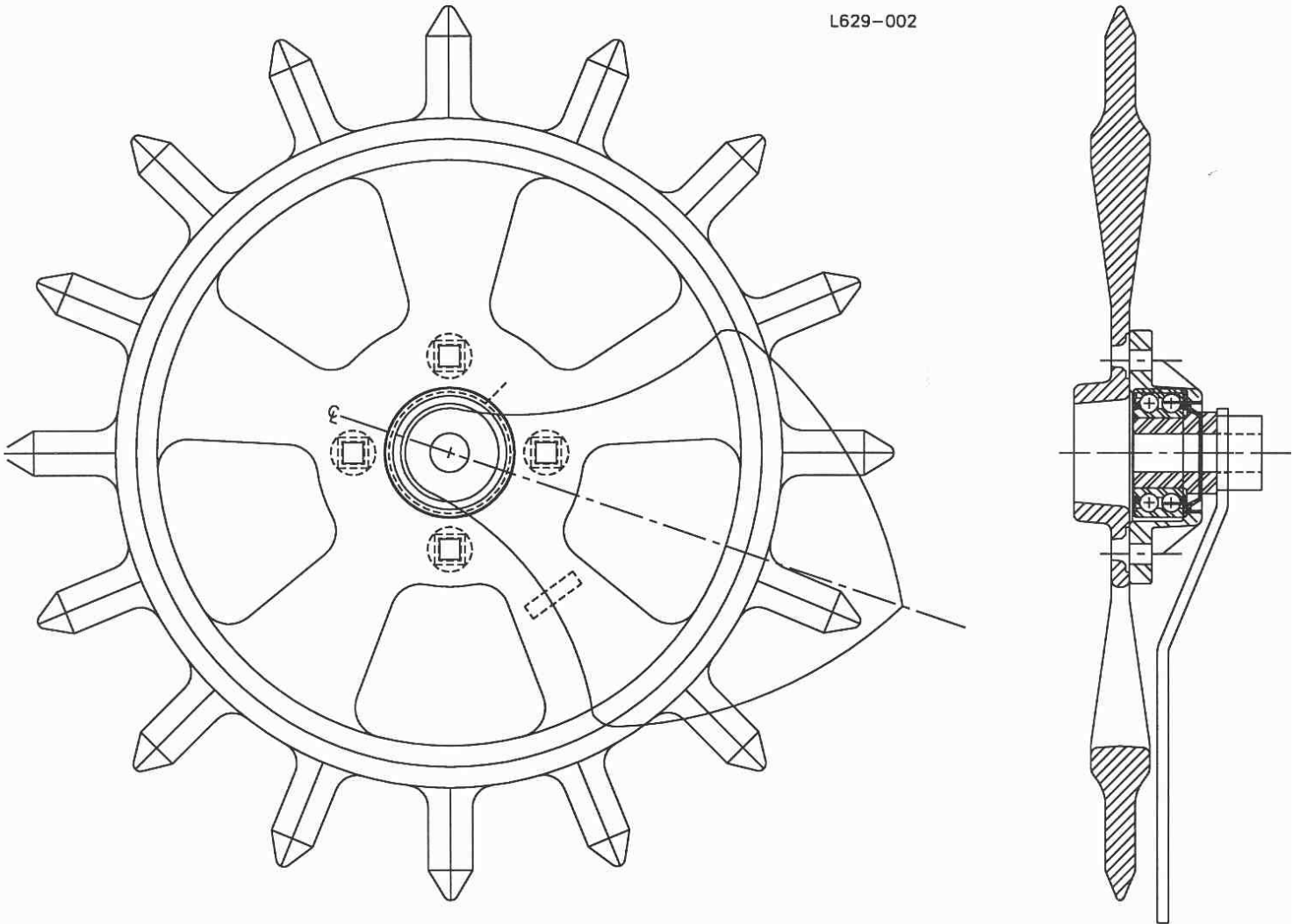

← FORWARD TRAVEL

NOTES:

NOTES:

NOTES:

Our name Is getting known

Just a few years ago, Yetter products were sold primarily to the Midwest only. Then we embarked on a program of expansion and moved into the East, the South, the West and now north into Canada. We're even getting orders from as far away as Australia and Africa.

So, when you buy Yetter products . . .you're buying a name that's recognized. A name that's known and respected. A name that's become a part of American agriculture and has become synonymous with quality and satisfaction in the field of conservation tillage.

Thank you.

YETTER MANUFACTURING CO.
Colchester, IL 62326-0358 • 309/776-4111
Toll Free 800/447-5777
Fax 309/776-3222
Website: WWW.YETTERCO.COM
E-MAIL: INFO@YETTERCO.COM

2565-734_REV_E 09/2014