



# **Combine Grain Tank Extension**

## **JOHN DEERE 9450/9550 SERIES**

### **OPERATORS / ASSEMBLY MANUAL**

**2002 MODEL COMBINES SERIAL # (9450)-695101 & UP (9550)-695201 & UP**

**PLACE IN COMBINE CAB AFTER ASSEMBLY  
FOR FUTURE REFERENCE.**

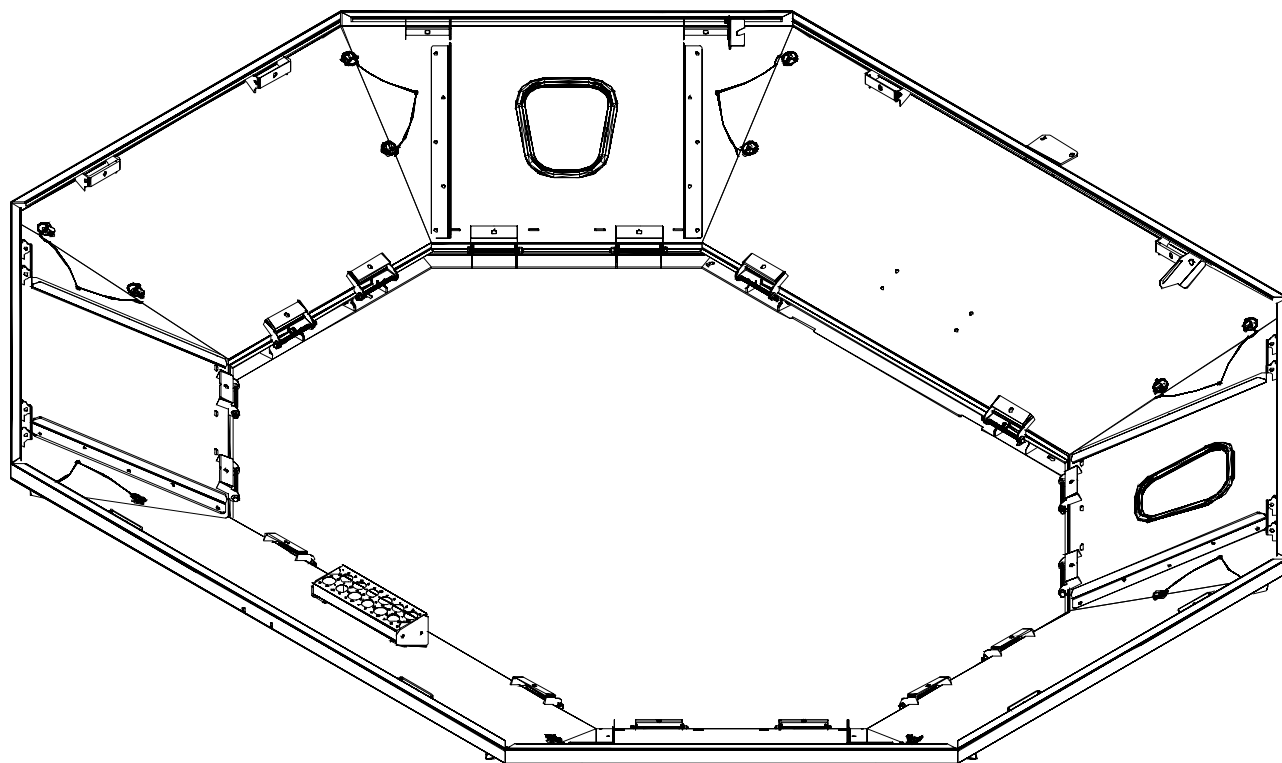

**ASSEMBLY  
OPERATION  
REPLACEMENT PARTS**

# INTRODUCTION

Thank you for purchasing a Maurer grain tank extension. Proper care and use will result in many years of service.



**WARNING:** TO AVOID PERSONAL INJURY OR DEATH, OBSERVE THE FOLLOWING INSTRUCTIONS:

Ensure that anyone present is clear before applying power to any machinery used in conjunction with a Maurer grain tank extension.

Never allow anyone in or near the grain tank of a combine during loading or unloading of grain. The accumulation of grain is dangerous and can cause entrapment, resulting in serious injury or death by suffocation.

Adding a Maurer Bin Extension or Tip-Up increases the overall height of your combine. Use caution when operating around trees, buildings, power lines, and when approaching bridges and over passes. Pay attention to height restrictions.

Do not exceed advertised maximum capacity of a Maurer grain tank extension.

## GENERAL INFORMATION

1. Read assembly instructions carefully. Study assembly procedures and all illustrations before you begin assembly. Note which parts are used in each step. This unit must be assembled in proper sequence or complications will result.
2. When placing a parts order, refer to this manual for proper part numbers and place order by **PART NO. and DESCRIPTION.**
3. Whenever terms "**LEFT**" and "**RIGHT**" are used in this manual it means from a position behind combine and facing forward.

## Table of Contents

General Information .....	2
Safety, Signal Words .....	3
Product Safety Guidelines .....	4
Safety Sign Locations .....	5
Safety Sign Care .....	5
Product Disclaimer .....	5
Parts Breakdown .....	6
Parts List .....	7
Frame Assembly .....	8
Panel Assembly .....	8-9
Misc. Bracket Assembly .....	10
Mounting Instructions .....	11
Complete Assembly, Tank Cap, Wiring, Bracing .....	12

## SAFETY

**TAKE NOTE! THIS SAFETY ALERT SYMBOL FOUND THROUGHOUT THIS MANUAL IS USED TO CALL YOUR ATTENTION TO INSTRUCTIONS INVOLVING YOUR PERSONAL SAFETY AND SAFETY OF OTHERS. FAILURE TO FOLLOW THESE INSTRUCTIONS CAN RESULT IN INJURY OR DEATH!**



**THIS SYMBOL MEANS  
ATTENTION  
BECOME ALERT  
YOUR SAFETY IS INVOLVED!**

### SIGNAL WORDS

Note use of following signal words **DANGER**, **WARNING**, and **CAUTION** with safety messages. The appropriate signal word for each has been selected using the following guidelines:

**DANGER:** Indicates an imminently hazardous situation that, if not avoided, will result in death or serious injury. This signal word is to be limited to most extreme situations typically for machine components which, for functional purposes, cannot be guarded.

**WARNING:** Indicates a potentially hazardous situation that, if not avoided, could result in death or serious injury, and includes hazards that are exposed when guards are removed. It may also be used to alert against unsafe practices.

**CAUTION:** Indicates a potentially hazardous situation that, if not avoided, may result in minor or moderate injury. It may also be used to alert against unsafe practices.

If you have questions not answered in this manual, require additional copies, or if your manual is damaged, please contact your dealer or Maurer Manufacturing, P.O. Box 160, 1300 38th Ave. West, Spencer, Iowa 51301, Ph: (712) 262-2992 Fax: (712) 262-1022 [www.maurermfg.com](http://www.maurermfg.com)



## **PRODUCT SAFETY GUIDELINES**

Every year many accidents occur which could have been avoided by a few seconds of thought and a more careful approach to handling equipment. You, the operator, can avoid many accidents by observing the following precautions in this section. To avoid personal injury, study the following precautions and insist those working with you, or you yourself, follow them.

Replace any caution, warning, danger or instruction safety decal that is not readable or is missing. Location of such decals is indicated in this booklet.

Review safety instructions with all users annually.

Operator should be a responsible adult. **DO NOT ALLOW PERSONS TO OPERATE OR ASSEMBLE THIS UNIT UNTIL THEY HAVE DEVELOPED A THOROUGH UNDERSTANDING OF SAFETY PRECAUTIONS AND HOW IT WORKS.**

Do not paint over, remove, or deface any safety signs or warning decals on your equipment. Observe all safety signs and practice instructions on them.

Never exceed limits of a piece of machinery. If it's ability to do a job, or to do so safely is in question **DON'T TRY IT.**

Adding a Maurer Bin Extension or Tip-Up increases the overall height of your combine. Use caution when operating around trees, buildings, power lines, and when approaching bridges and over passes. Pay attention to height restrictions.

Fold and secure (if needed) the grain tank extension panels when transporting the combine to avoid contact with low power lines and other obstructions.

Use the panel safety step to safely enter and exit the grain tank.

Ensure that any additional bracing and safety equipment have been installed according to this manual. (Some models do not require additional bracing or safety equipment)

Ensure that the grain tank extension frame has been properly mounted to the combine according to this manual.

Never exceed the maximum advertised capacity of the grain tank extension. By doing so you risk damage to the grain tank extension.



## SAFETY SIGN LOCATIONS

Types of safety sign and locations on equipment are shown in illustration below. Good safety requires that you familiarize yourself with various safety signs, type of warning, and area or particular function related to that area, that requires your SAFETY AWARENESS.

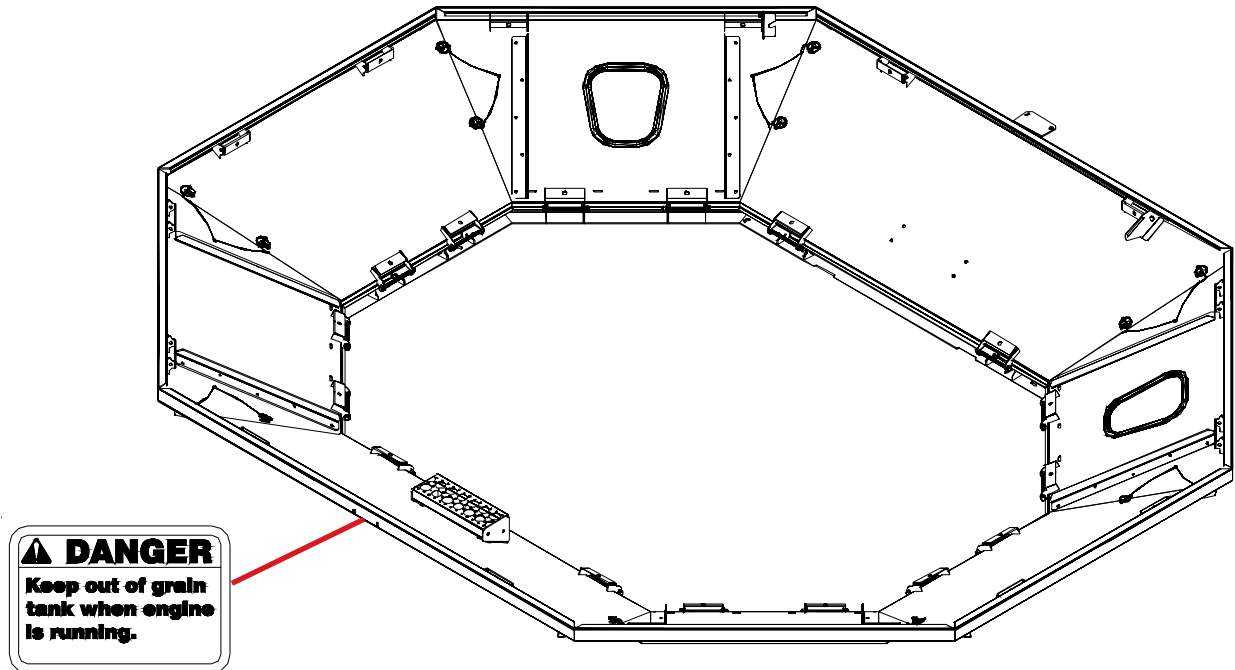

## SAFETY SIGN CARE

- Keep safety signs clean and legible at all times.
- Replace safety signs that are missing or have become illegible.
- Replacement parts that displayed a safety sign should also display current sign.
- Safety signs are available from the Spencer plant.

## PRODUCT DISCLAIMER

Increasing the grain tank capacity of any combine by use of this product is at the discretion of the owner. Increasing the grain holding capacity of any combine may affect the structural aspects of the combine as well as drive line components and tires. Although Maurer Mfg. has included additional support bracing on selected models, it does not assume liabilities, or make any warranties pertaining to the structural stability or performance of any combine. See the combine owners/operators manual for additional combine specifications and safety information not listed in this manual.

# Grain Tank Extension Breakdown

## John Deere 9450/9550 Series Grain Tank Extension

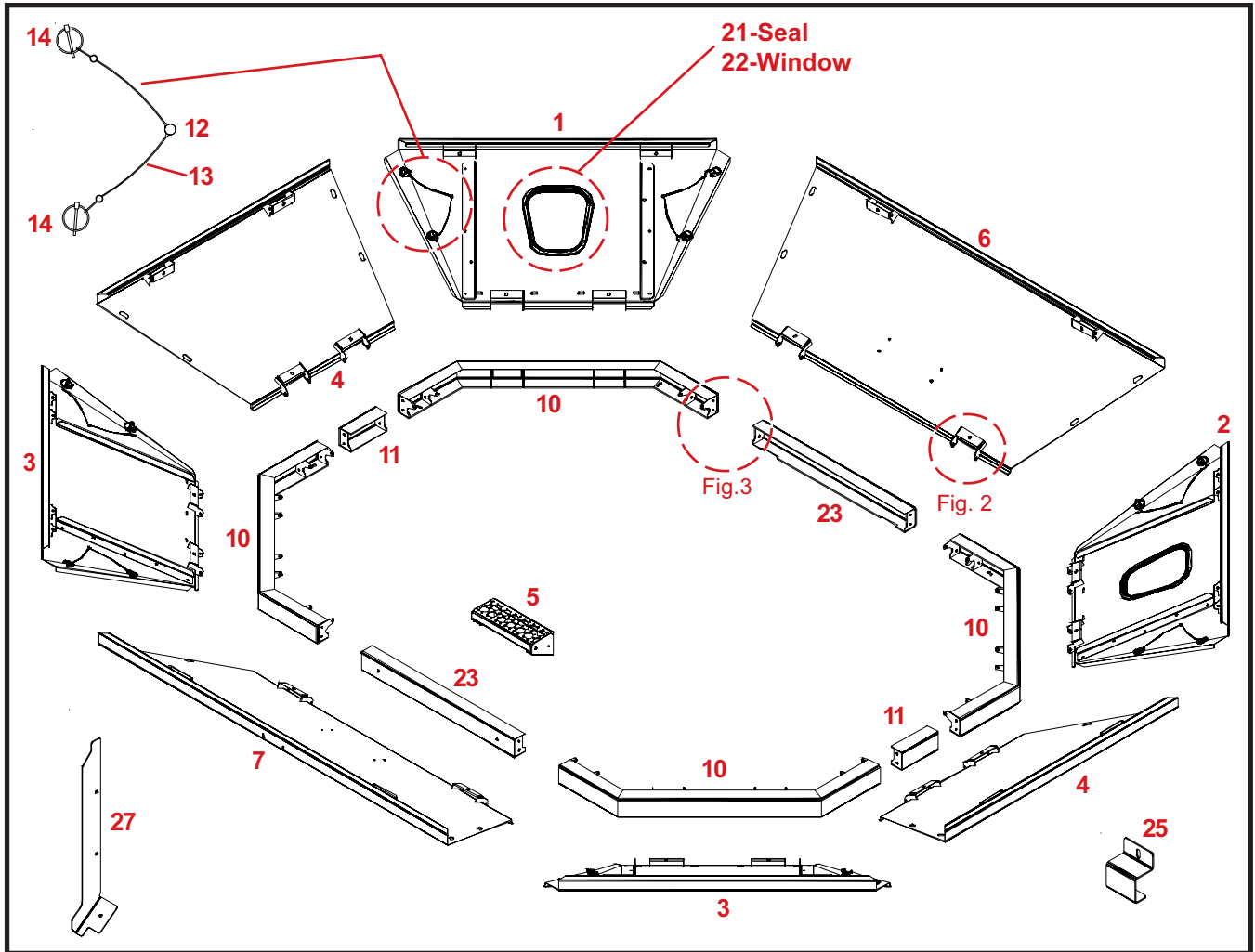

Figure 1

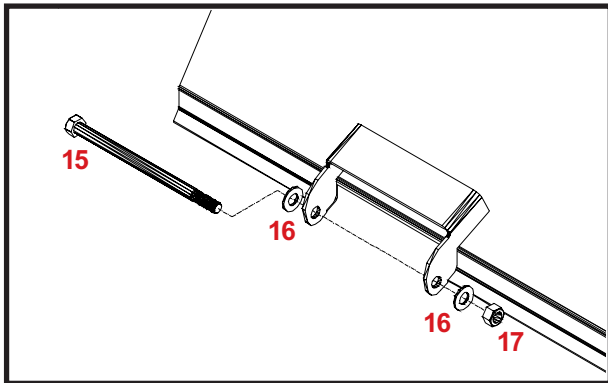

Figure 2

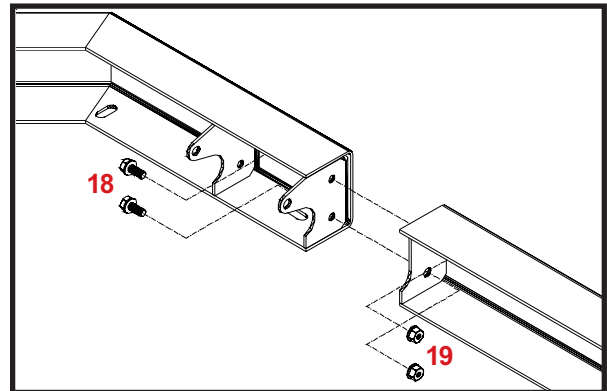

Figure 3

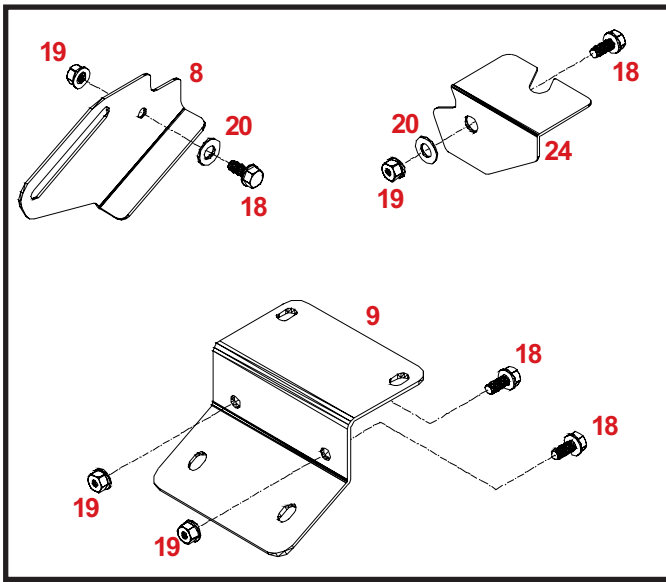

Figure 4

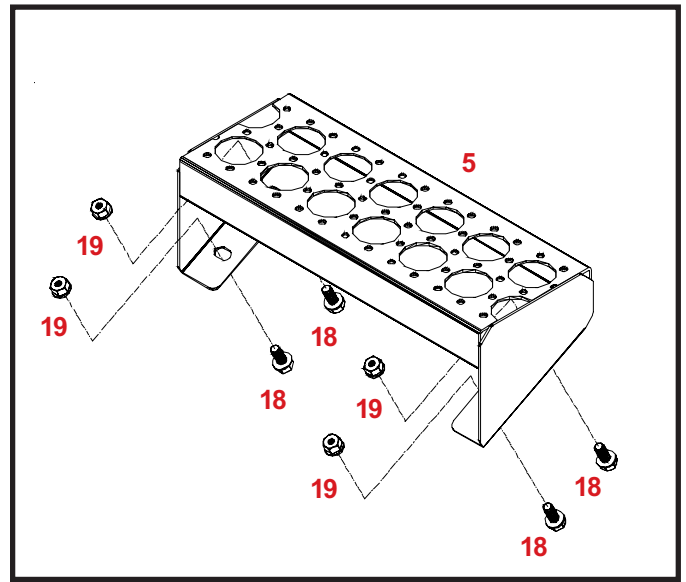

Figure 5

### PARTS LIST

Please order replacement parts by PART NO. and DESCRIPTION.

REF #	PART #	QTY.	DESCRIPTION
1.	R5E000011P0	1	Front Left Corner Panel
2.	R5E000003P0	1	Front Right Corner Panel
3.	R5E000005P0	2	Rear Corner Panel
4.	R5E000020P0	2	Side Panel (9000 Series)
5.	R5E000006P0	1	Extension Safety Step
6.	R5E000018P0	1	Front Panel (9000 Series)
7.	R5E000019P0	1	Rear Panel (9000 Series)
8.	R3E000019P0	1	Base Sensor Bracket
9.	R3E000022P0	1	Base GPS Bracket
10.	R5E000007P0	4	Frame Corner Assembly
11.	R5E000024P0	2	Frame Splice Side Assembly
12.	1AF032D0000	8	Press Rivet
13.	1AF031DKA00	16	Nylon Lanyard
14.	1AF034CAA10	16	3/16" x 1-9/16" Lynch Pin
15.	1AFC12FFA05	16	3/8" x 6" Hex Bolt
16.	1AF009E000C	32	3/8" SAE Flat Washer
17.	1AFC18F0000	16	3/8" Nylon Lock Nut
18.	1AFC37E00L0	43	5/16" x 3/4" Serrated Flange Bolt
19.	1AFC08E0000	43	5/16" Serrated Flange Nut
20.	1AF046EAAD0	2	5/16" x 1-1/4" x .120 Washer
21.	R3E000026P0	2	Window Seal
22.	1AWALACKAMC	2	Window
23.	R5E000025P0	2	Frame Splice Front & Rear Assembly
24.	R3E000003P0	1	Base Light Bracket
25.	R3E000020P0	4	Frame/Tank Hold Down Bracket
26.	*1AFC35CAA00	19	#12 x 1" Self Tapping Screw
27.	R3E000047P0	1	Right Tank Brace
28.	1AFC35FAA00	1	5/16" x 1" Self Tapping Bolt
29.	R3E000074P0	1	9450/9550 Mounting Bracket
30.	R3E000075P0	1	9450/9550 Mounting Plate
31.	R3E000043P0	2	Rear Tank Cap
32.	R3E000044P0	2	Front Tank Cap
33.	*1AEX0015241	1	Deere Wire Harness

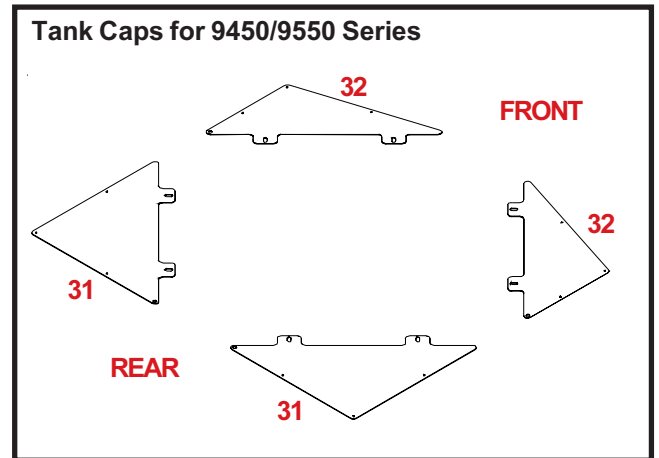

Figure 6

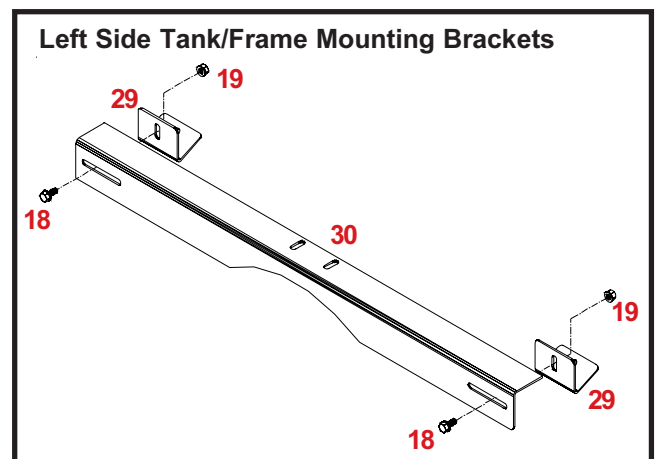

Figure 7

\* Indicates items not shown in illustrations

**NOTE:** In order to simplify the assembly process, we recommend that the grain tank extension be assembled on the ground and hoisted to the top of the combine.

## **FRAME ASSEMBLY**

Arrange the frame components as shown in figure 8. The frame corner with the serial number decal is the left front frame corner. Fasten the frame joints together with two 5/16" x 3/4" serrated flange bolts and two 5/16" serrated flange nuts per joint. See figure 8A.

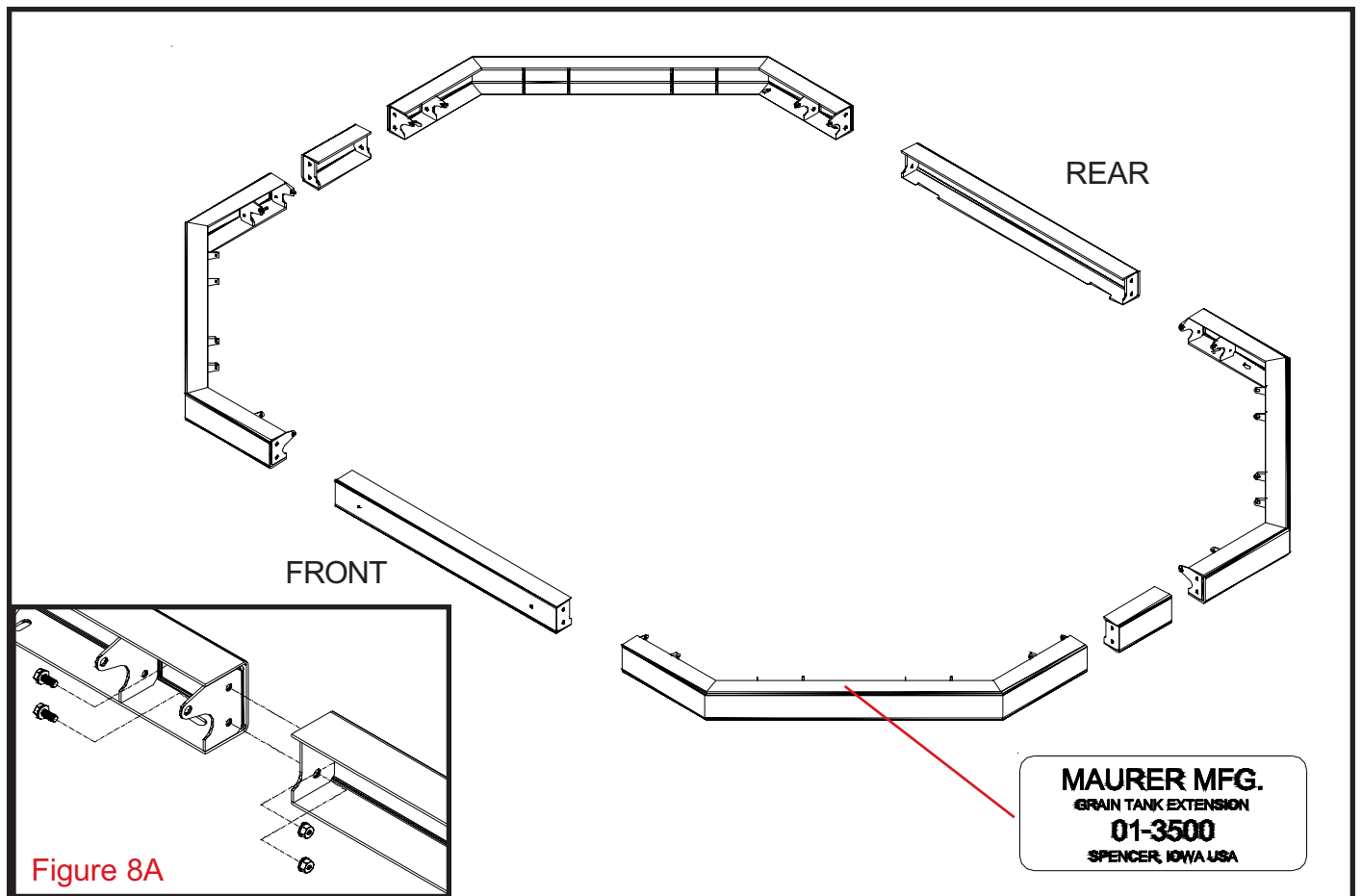

Figure 8

## **PANEL ASSEMBLY**

### **STEP 1:**

Using one 3/8" x 6" hex bolt, two 5/16" washers and one 3/8" nylon lock nut per hinge point, attach the extension corner panels to the frame of the grain tank extension. See figure 9A.

**NOTE:** DO NOT over tighten nuts and distort hinge component, but ensure nylon lock nut fully engages bolt threads.



## **STEP 2:**

Assemble all four corner panels to the frame (panels with windows are to be fastened to the front) and slowly fold the panels outward to accept the front, rear, and side panels. The corner panel with the Maurer logo on the back side is the left front corner. See figure 9.



**ATTENTION:** DAMAGE TO CORNER PANEL CAN OCCUR IF NOT FOLDED OUTWARD SLOWLY!

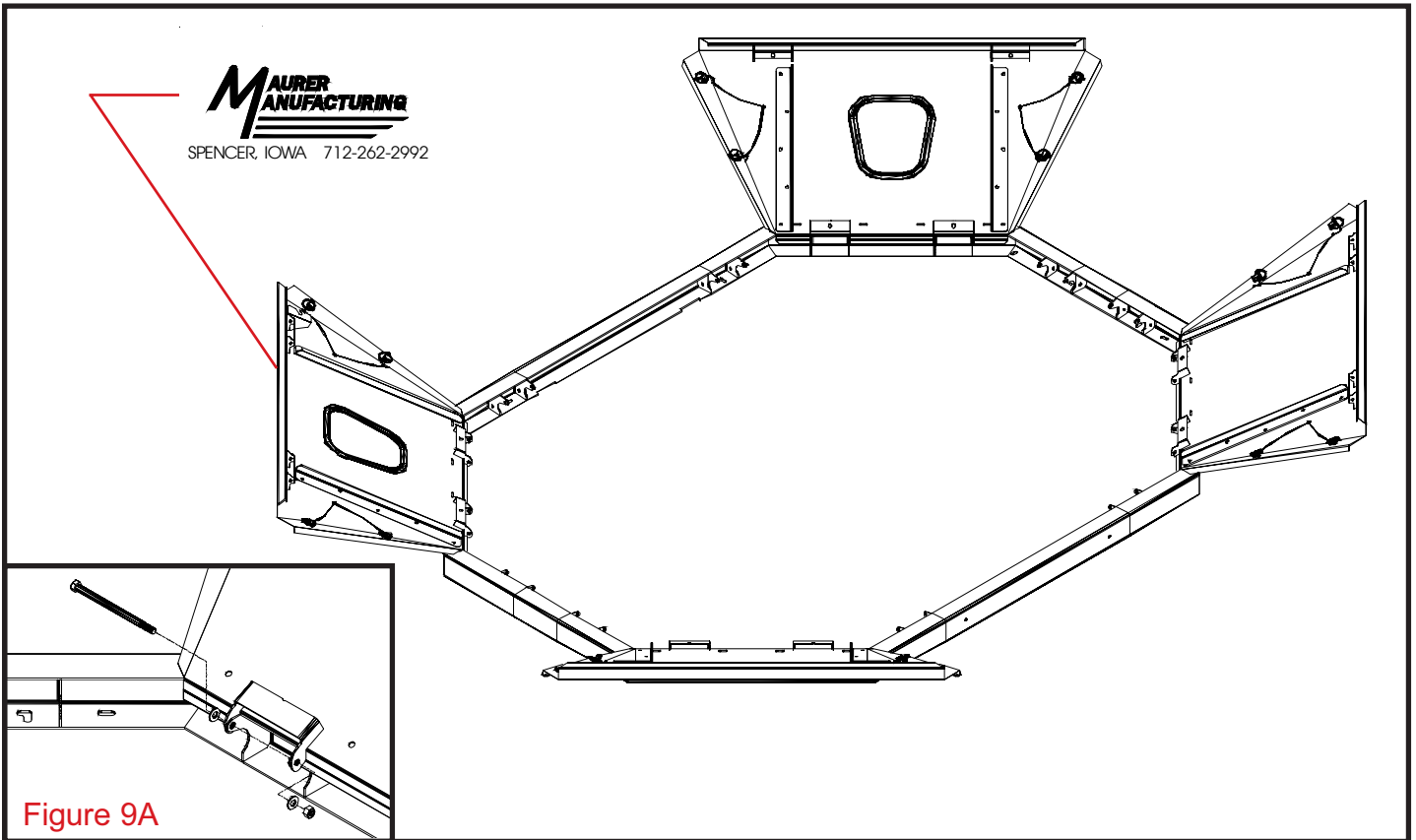

Figure 9

## **STEP 3:**

Assemble the front, rear, and side panels the same as the corner panels. Please ensure that the panel with DANGER decal is the rear panel. This panel will also receive the safety step.

## **STEP 4:**

Remove the partial cut slugs near the bottom of the rear panel, and fasten the safety step to the rear panel using 5/16" x 3/4" serrated flange bolts and 5/16" serrated flange nuts. When mounting, place the nuts to the inside. See figure 10.

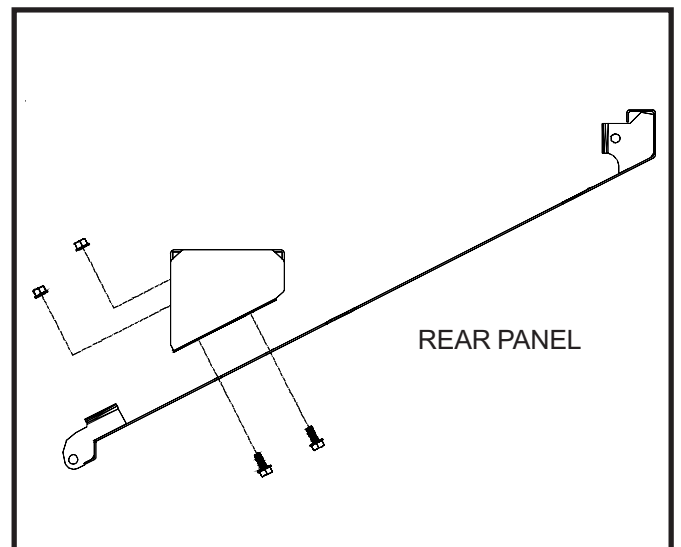

Figure 10



**ATTENTION:** DANGER decal must be facing the rear of the combine!

**STEP 5:**

Fasten the tank full sensor bracket to the right front corner using one 5/16" x 3/4" serrated flange bolt, one 5/16" serrated flange nut, and one 5/16" x 1-1/4" x .120 washer. See figure 11.

**STEP 6:**

Fasten the provided light bracket to the left front corner using one 5/16" x 3/4" serrated flange bolt, one 5/16" serrated flange nut, and one 5/16" x 1-1/4" x .120 washer. See figure 12.

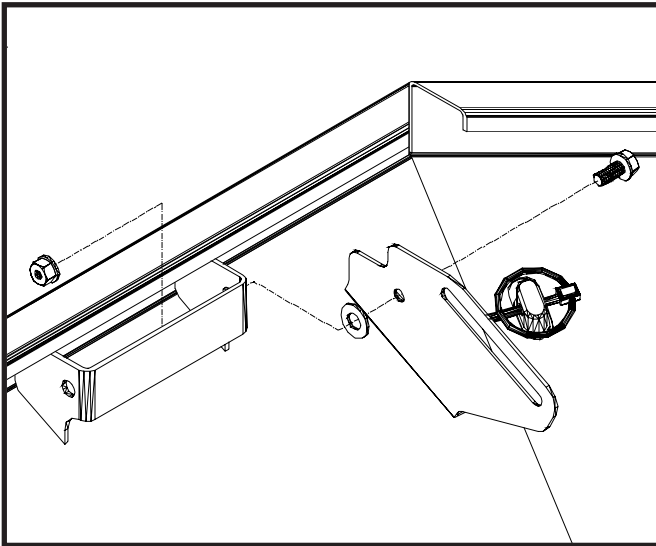

Figure 11

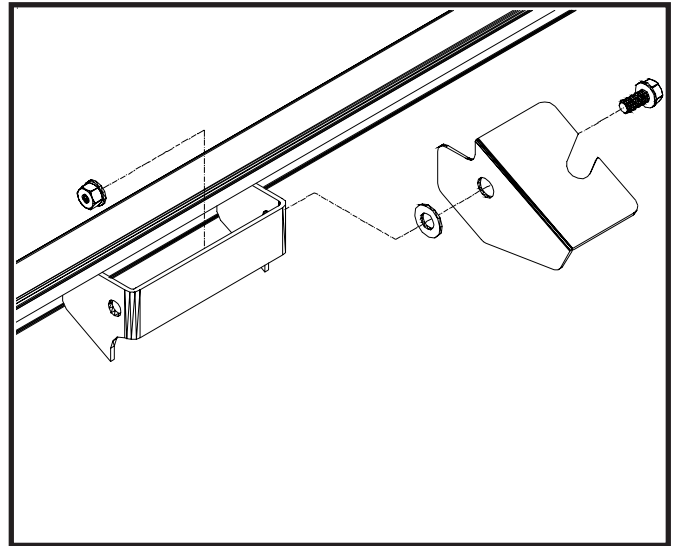

Figure 12

**STEP 7:**

Remove the partial cut slugs from the vertical leg of the front panel, and mount the base GPS bracket using two 5/16" x 3/4" serrated flange bolts and two 5/16" serrated flange nuts. See figure 13.

**STEP 8:**

Align two nylon lanyards with one press rivet and fasten together. Loop and lock the ends of the lanyards around one lynch pin each. Fasten the complete assembly to the two small holes located on the corner panels. See figure 16.

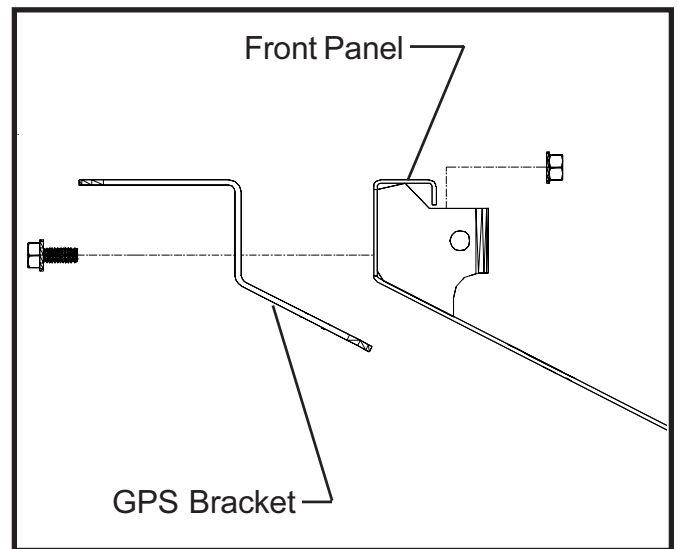

Figure 13

## MOUNTING INSTRUCTIONS

### STEP 1:

Remove the two OEM tank brackets from the left side of the tank. Keep the original hardware to fasten Maurer tank brackets in step two. See figure 14. (9450 does not have the mentioned tank brackets shown in figure 14A skip to step two)

### STEP 2:

Loosely fasten the two Maurer mounting brackets to the mounting plate using one 5/16" serrated flange bolt and one 5/16" serrated nut per bracket. Align the slots in the brackets with the newly exposed holes on the left side of the tank and fasten to tank using the original hardware. Once assembled to the tank tighten the mounting plate to the mounting brackets. See figure 14.

### STEP 3:

Hoist the assembled grain tank extension to the top of the combine. Position over the grain tank and carefully lower into place with the window panels facing front.

### STEP 4:

Rest the right side of the extension frame on the two existing tank brackets along the top of the right side. Once aligned with the right side be sure the frame is also square front to rear.

### STEP 5:

Using the provided tank hold-down brackets, secure the frame to the tank using one 5/16" X 3/4" serrated flange bolt and 5/16" serrated flange nut per bracket. Slide the hold-down upward to create clamping action before tightening. The hold-down will fit into the notch on the bottom lip of the front and back frame sections. See figure 15.

### STEP 6:

Finish mounting the extension frame to the tank by fastening the already positioned left frame/tank mounting plate to the left side of the extension frame. One slot in the frame will align with the slot in the mounting plate, secure with one 5/16" serrated flange bolt and nut.

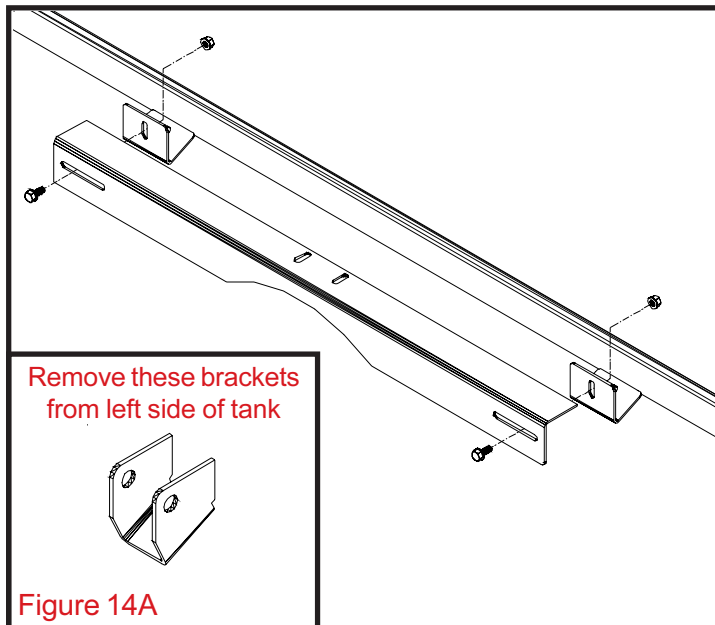

Figure 14

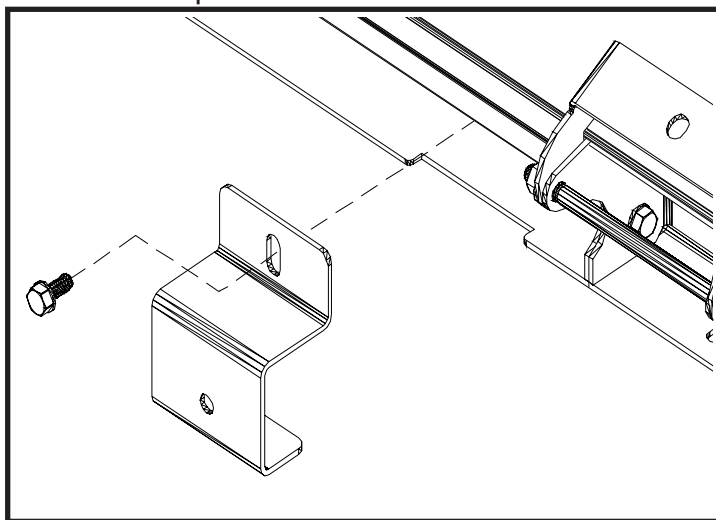

Figure 15



**ATTENTION:** Failure to properly tighten hold-down brackets could result in equipment damage.

## Completed Grain Tank Extension Assembly

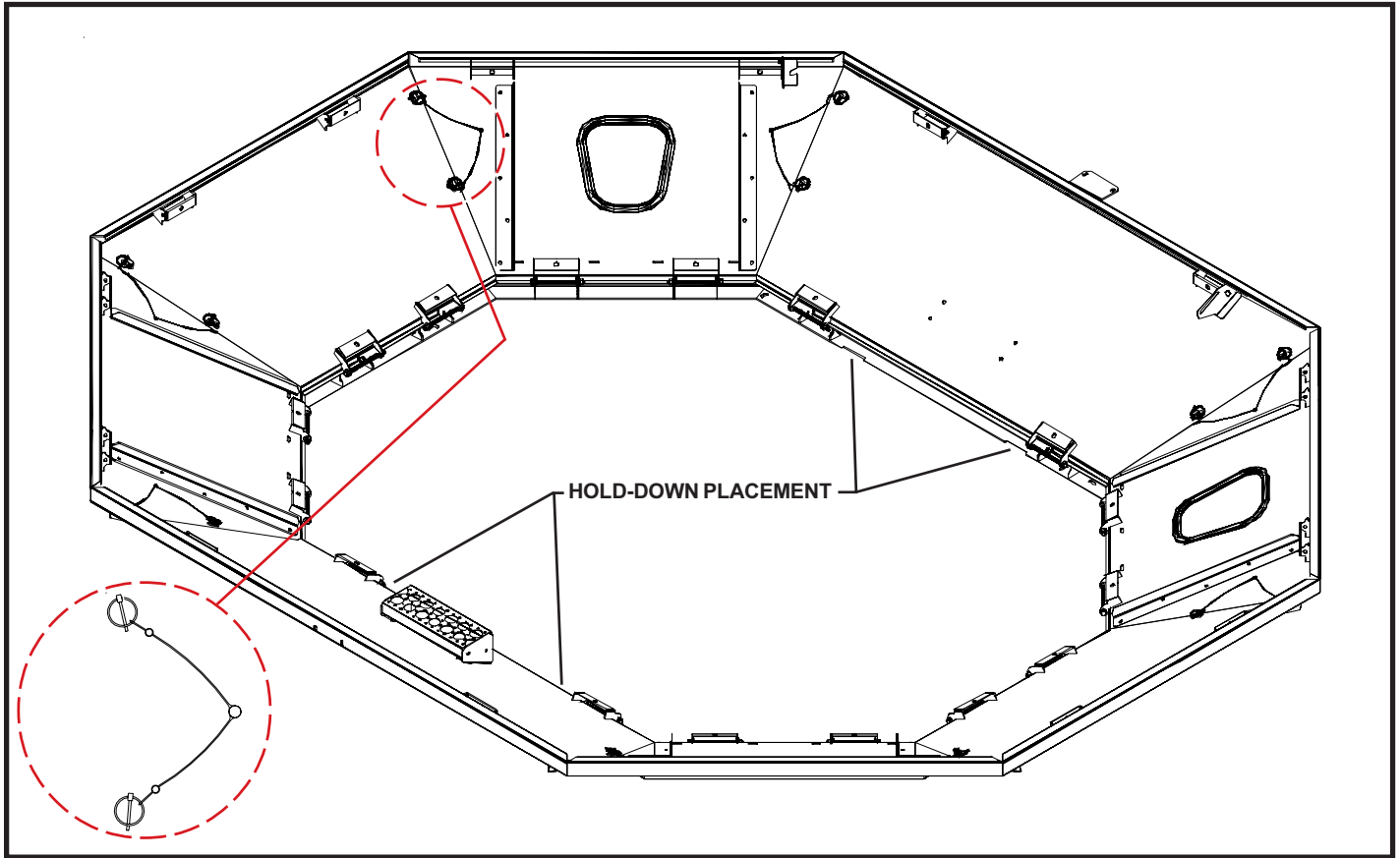

Figure 16

### **TANK CAPS**

Fasten Tank Caps to the extension frame corners using 5/16" serrated bolts and 5/16" serrated flange nuts. (Tabs will be on the underside of frame) Complete by screwing the Tank Caps to the outer rim of the tank with #12 x 1" screws. The smaller triangular parts are the front Tank Caps, the larger parts the rear Tank Caps. Reference page 7.

### **SENSOR / LIGHT WIRING**

Mount the OEM light to the already mounted light bracket on the left front corner. Fasten with the original hardware. Mount the sensor to the slot in the bracket using the original hardware. Use the provided wire harness to connect the sensor to the OEM wiring. Clip and extend the wiring for the tank light.

### **TANK BRACING**

Install the right tank brace to the vertical support located on the inside of the rear tank wall using three 5/16" self tapping screws. See figure 17.

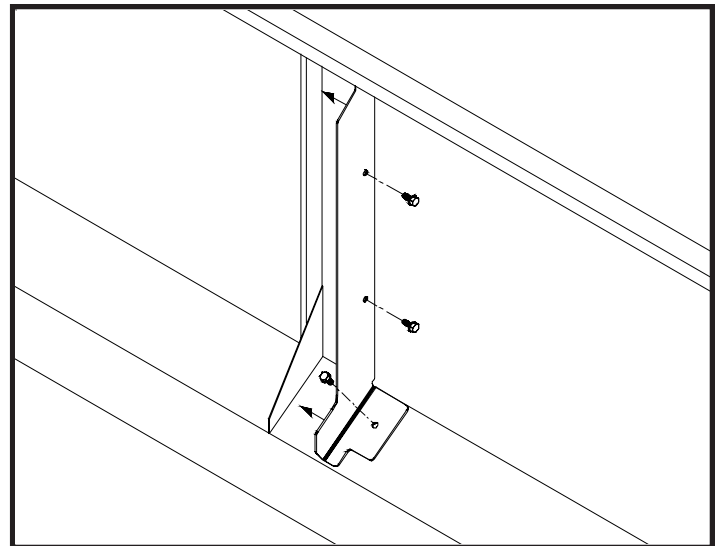

Figure 17



**ATTENTION:** Failure to use bracing can result in damage to tank.