

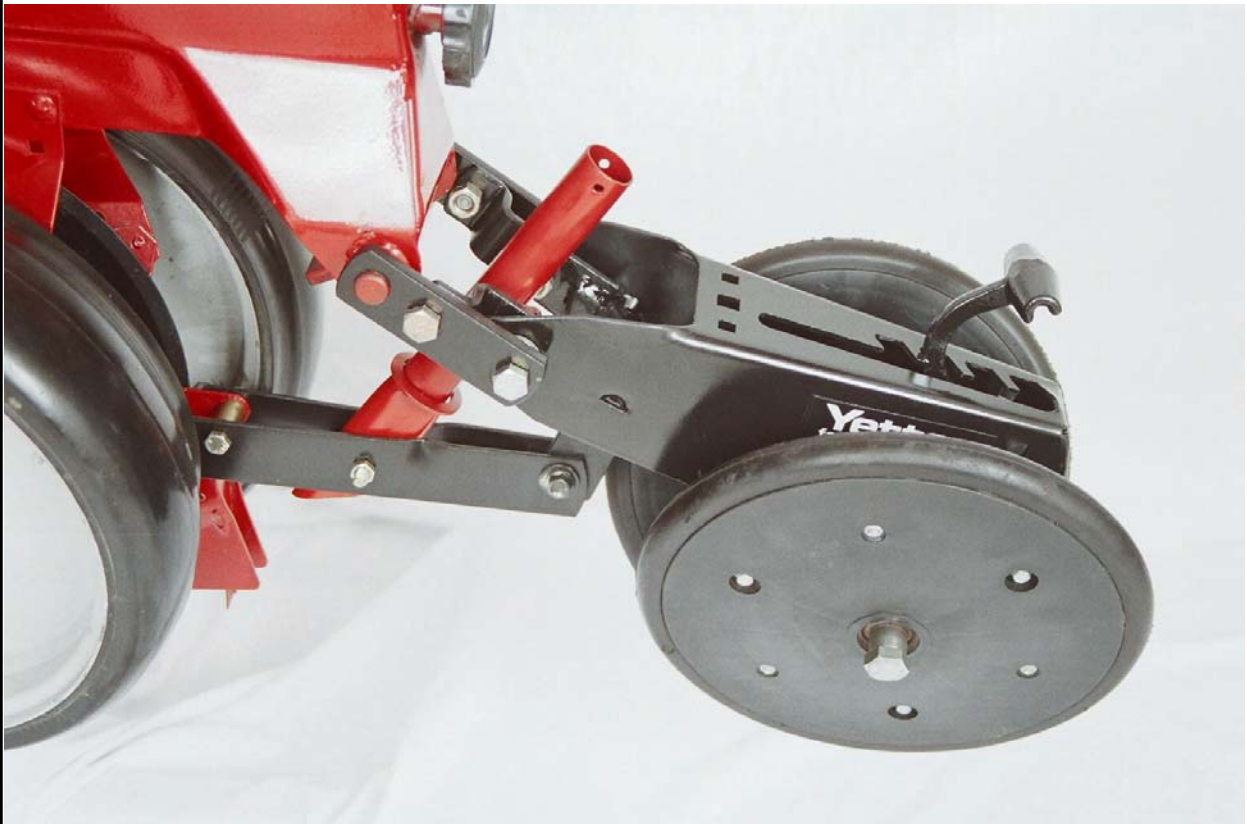

**INSTRUCTION MANUAL
AND PARTS CATALOG
V-CLOSE WHEEL KIT
CNH ROW UNIT**



YETTER MANUFACTURING CO.
FOUNDED 1930

Colchester, IL 62326-0358
Toll free: 800/447-5777
309/776-3222 (Fax)
Website: www.yetterco.com
E-mail: info@yetterco.com

YETTER

FOREWORD

You've just joined an exclusive but rapidly growing club.

For our part, we want to welcome you to the group and thank you for buying a Yetter Product.

We hope your new Yetter implement will help you achieve both increased productivity and increased efficiency so that you may generate more profit. This operator's manual has been designed into six major sections.

Foreword, Safety Precautions, assembly instructions, Operation, parts identification and troubleshooting.

It is important the owner/operator knows the implement model number. Write the model number in the space provided and use it in all correspondence when referring to the implement.

Throughout the manual references may be made to left side and right side. These terms are used as viewed from the operator's seat facing the front of the tractor.



This **SAFETY ALERT SYMBOL** indicates important safety messages in the manual. When you see this symbol, be alert to the possibility of **PERSONAL INJURY** and carefully read the message that follows.

The word **NOTE** is used to convey information that is out of context with the manual text. It contains special information such as specifications, techniques, reference information

and other information of a supplementary nature.

The word **IMPORTANT** is used in the text when immediate damage will occur to the machine due to improper technique or operation. Important will apply to the same information as specified by note only of an immediate and urgent nature.

It is the responsibility of the user to read the operator's manual and comply with the safe and correct operating procedure and to lubricate and maintain the product according to the maintenance schedule in the operator's manual.

The user is responsible for inspecting his machine and for having parts repaired or replaced when continued use of the product would cause damage or excessive wear to the other parts.

It is the user's responsibility to deliver his machine to the Yetter dealer who sold him the product for service or replacement of defective parts that are covered by the warranty policy.



If you are unable to understand or follow the instructions provided in the publication, consult you local Yetter dealer or contact:

YETTER MANUFACTURING CO.

309/776-4111

800/447-5777

309/776-3222 (FAX)

Website: www.yetterco.com

E-mail: info@yetterco.com

WARRANTY POLICY

Yetter Manufacturing warrants all products manufactured and sold by it against defects in material. This warranty being expressly limited to replacement at the factory of such parts or products as will appear to be defective after inspection. This warranty does not obligate the Company to bear cost of labor in replacement of parts. It is the policy of the company to make improvements without incurring obligations to add them to any unit already sold. No warranty is made or authorized to be made, other than herein set forth. This warranty is in effect for one year after purchase.

Model Number: _____

Dealer : _____

Yetter Manufacturing warrants its own products only and cannot be responsible for damage to equipment on which it is mounted.

SAFETY

A brief description of signal words that may be used in this manual:

CAUTION: Used as a general reminder of good safety practices or to direct attention to unsafe practices.

WARNING: Denotes a specific potential hazard.

DANGER: Denotes the most serious specific potential hazard.

SAFETY PRECAUTIONS

You can make your farm a safer place to live and work if you observe the safety precautions given. Study these precautions carefully and insist that those working with you and for you follow them.

Finally, remember this: an accident is usually caused by someone's carelessness, neglect or oversight.



WARNING

Never clean, lubricate or adjust a machine that is in motion. Always lower or block the implement before performing service.

If the machine must be serviced in the raised position, jack or block it up to prevent it from accidentally falling and injuring someone.

Do not allow riders on the tractor or implement.

Use speeds and caution dictated by the terrain being traversed. Do not operate on any slope steep enough to cause tipping or loss of control.

Be sure all personnel are clear of the immediate area before operating.

Read and understand the operator's manual and require all other persons who will operate the equipment to do the same.

Be familiar with all tractor and implement controls and be prepared to stop engine and implements quickly in an emergency.



CAUTION

Consult your implement and tractor operator's manual for correct and safe operating practices.

Beware of towed implement width and allow safe clearance.

FAILURE TO HEED MAY RESULT IN PERSONAL INJURY OR DEATH.

ASSEMBLY INSTRUCTIONS

STEP 1. Remove the covering disc and the press wheel from the row unit.

STEP 2. Attach the 6200-306 L.H. spring anchor and 6200-305 R.H. spring anchor to the row unit using a 3/8" x 2" bolt, spacer and lock nut.

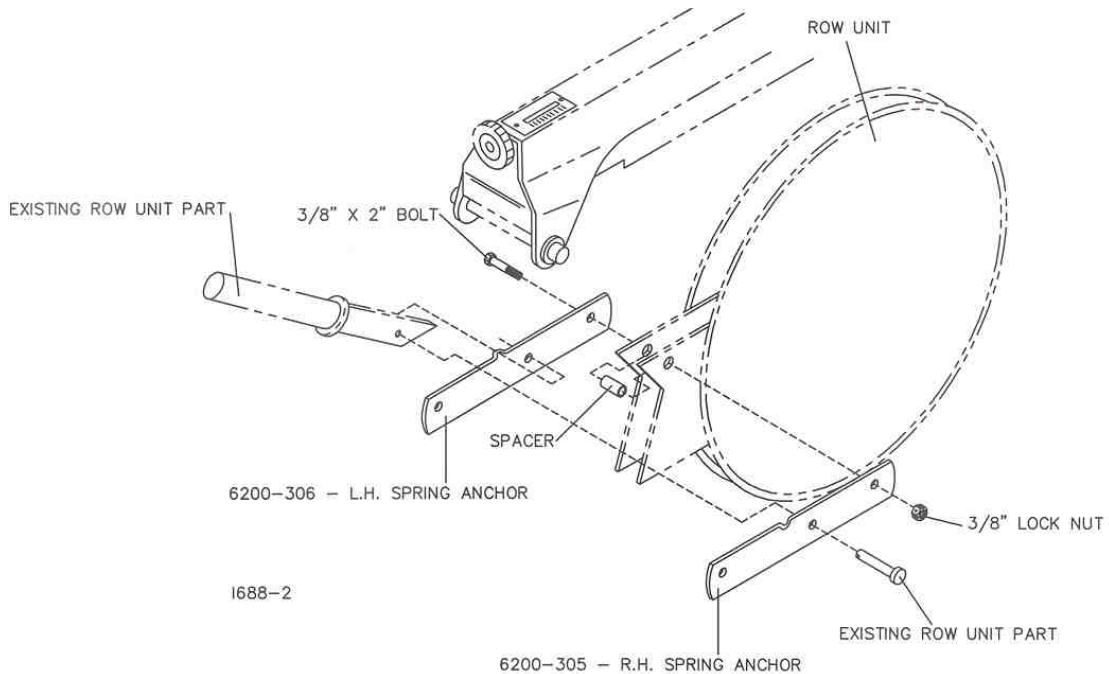

STEP 3. Attach the 6200-202 - v-closing wheel mount to the spring anchor straps using a 3/8" x 1-1/2" bolt, 3/8" flat washer, spacer, 3/8" flat washer and lock nut.

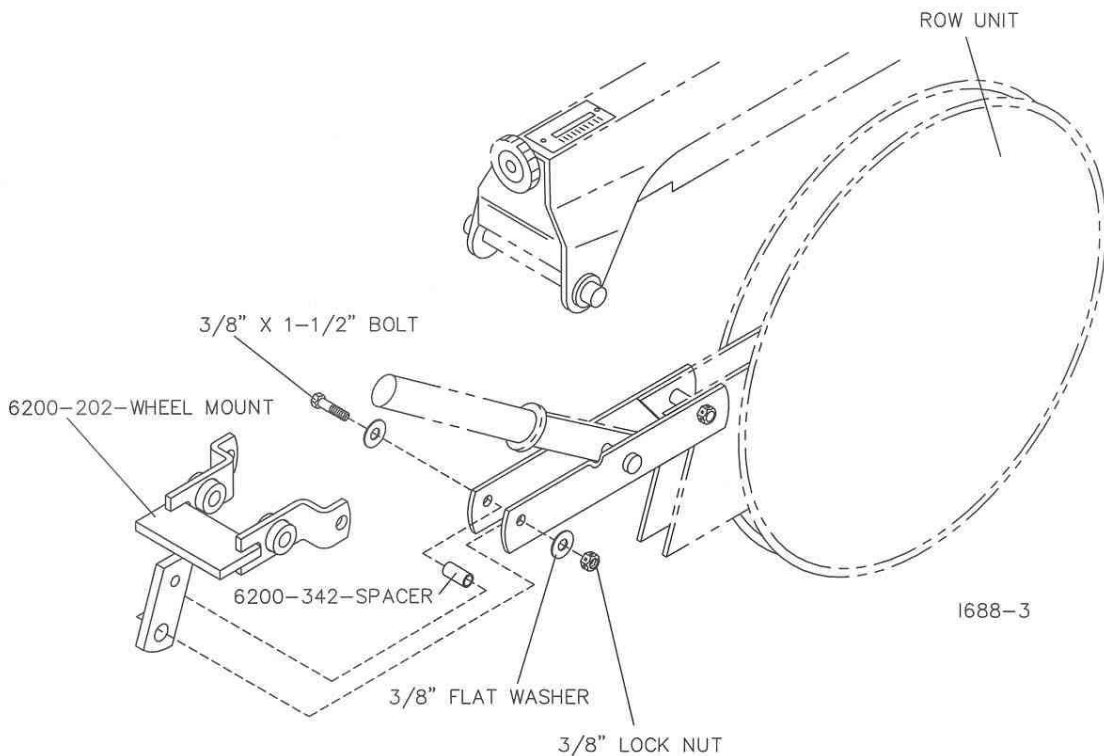

ASSEMBLY INSTRUCTIONS

STEP 4. Insert the 6000-524 – close wheel lever into the 6000-247 close wheel arm, install the spring onto the close wheel lever and attach the close wheel lever to the wheel arm using a 5/16" x 1-1/2" bolt and lock nut.

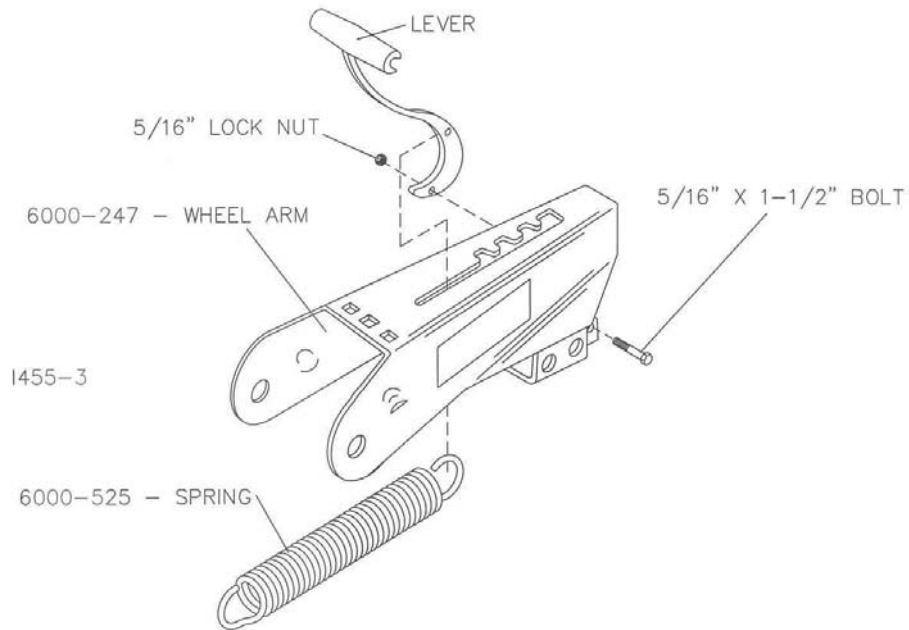

STEP 5. First, hook the spring onto the 6200-202 – close wheel mount then attach the close wheel arm assembly to the left hand side of the 6200-202 close wheel mount and the row unit using the 1/2" x 1" bolt, 6200-341 – link and lock nut. Insert the 6000-523 – eccentric bushing into the close wheel arm and connect the close wheel arm to the 6200-341 - link and 6200-202 – wheel mount using a 1/2" x 2-1/2" bolt, 1/2" flat washer and lock nut.

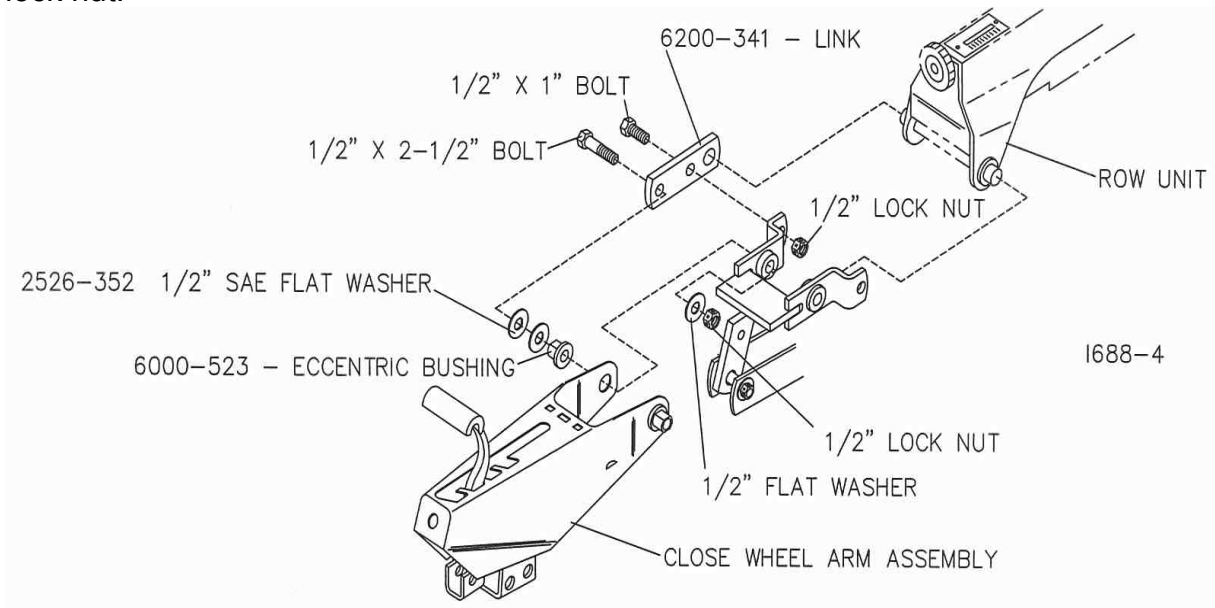

ASSEMBLY INSTRUCTIONS

STEP 6. Attach the close wheel arm assembly to the right hand side of the 6200-202 – close wheel mount and the row unit by inserting the 6000-523 – eccentric bushing into the close wheel arm assembly and securing with the 1/2" x 2-1/2" bolt, link, 1/2" flat washer and lock nut. Attach the link to the close wheel bracket using a 1/2" x 1" bolt and lock nut.

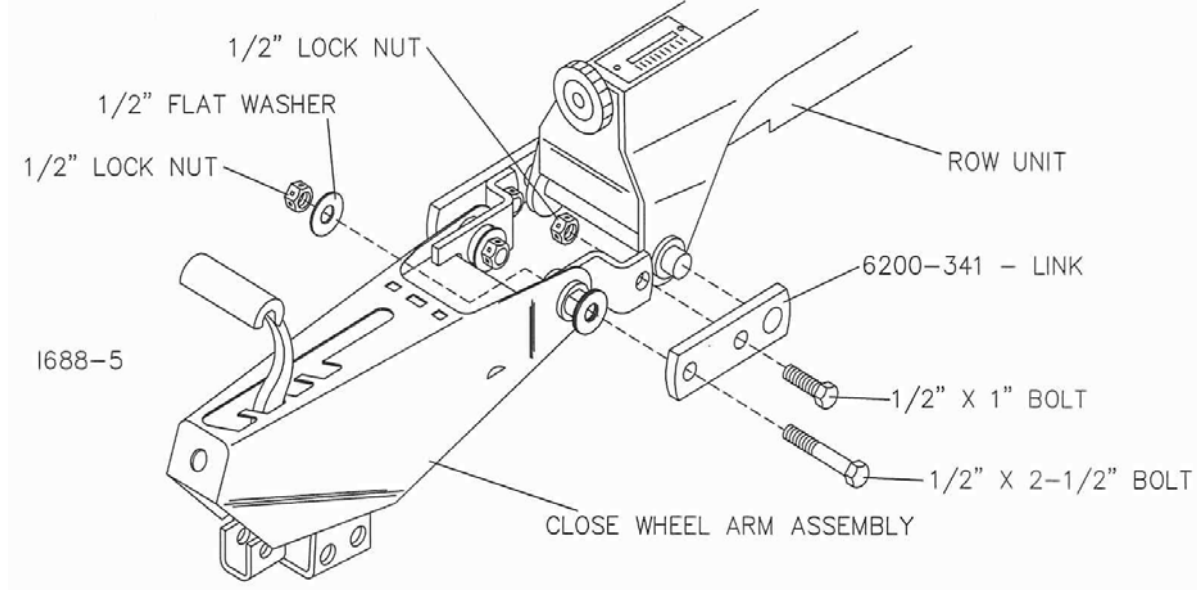

STEP 7. Attach the wheels to the 6000-247 arm using a 5/8" x 4" bolt, flat washer, bushing, spacer and 5/8" lock nut.

NOTE: In certain conditions, seed to soil contact and residue flow can be improved by spacing closing wheels further apart and or staggering them. To space closing wheels further apart place the spacers, washers and bushings between the closing wheel and the arm. To remove space between wheels, place the spacers, washers and bushings on outside of wheel. Two mounting holes, for each closing wheel are provided to stagger closing wheels. To stagger closing wheels remove one closing wheel from the arm and reassemble in the other hole.

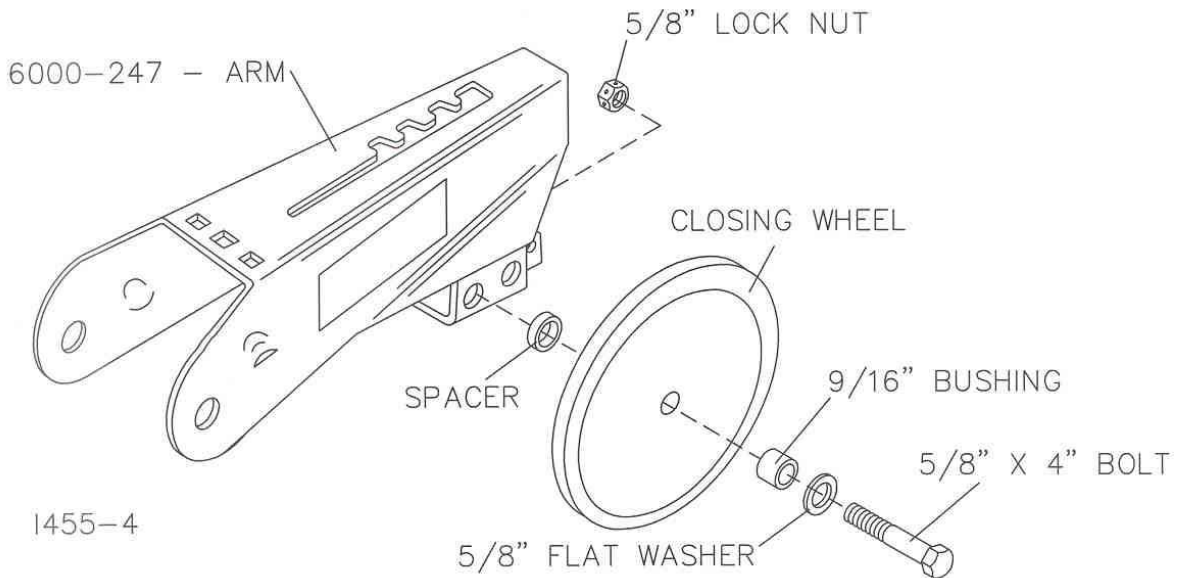

“V” CLOSING WHEEL ADJUSTMENT

▲ CAUTION: Raise planter to transport position and install all safety locks before adjusting closing wheels.

Angled closing wheels trail behind seed opener to close seed trench left by opener. Adjustable spring pressure permits proper firming of the soil beside seed runner rather than directly above it. An eccentric bushing allows centering of the closing wheel on the row to properly apply pressure on both sides of the seed when closing the trench. When adjusted properly, the closing wheels are centered.

NOTE: For clarity, closing wheel assembly has been removed from row unit.

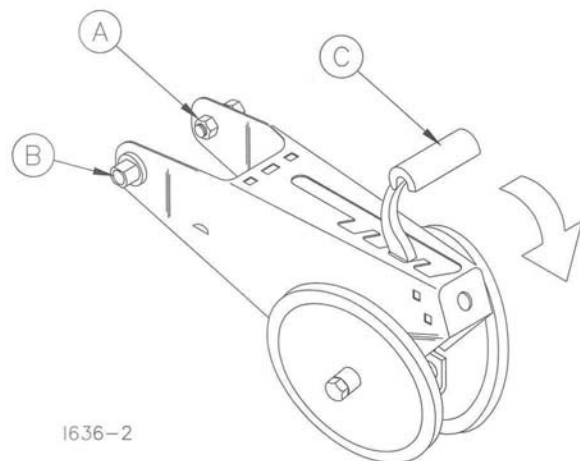

Loosen bolts (A) that attach closing wheel arm to wheel arm stop.

Rotate eccentric bushing (B) with wrench to align closing wheel assembly with center of seed trench.

Tighten bolts (A) that attach closing wheel arm to wheel arm stop.

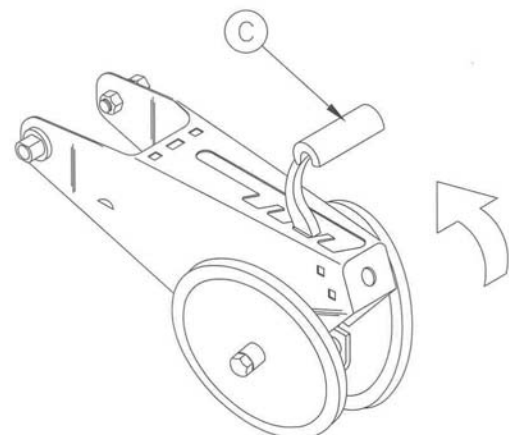

After setting planting to correct depth, check operation of closing wheels.

The closing wheel must apply enough down pressure to close the seed

trench and insure good seed-to-soil contact.

If the seed trench is NOT being closed properly, INCREASE closing wheel pressure by moving lever (C) REARWARD.

Closing wheels must NOT sink into the soil too deeply or the seed placement could be adversely affected, especially when planting shallow.

If the closing wheels are applying too much pressure and the seed is being moved by the closing wheels, DECREASE closing wheel pressure by moving lever (C) FORWARD.

Light soils usually require LESS down pressure; heavy soils MORE.

PARTS IDENTIFICATION

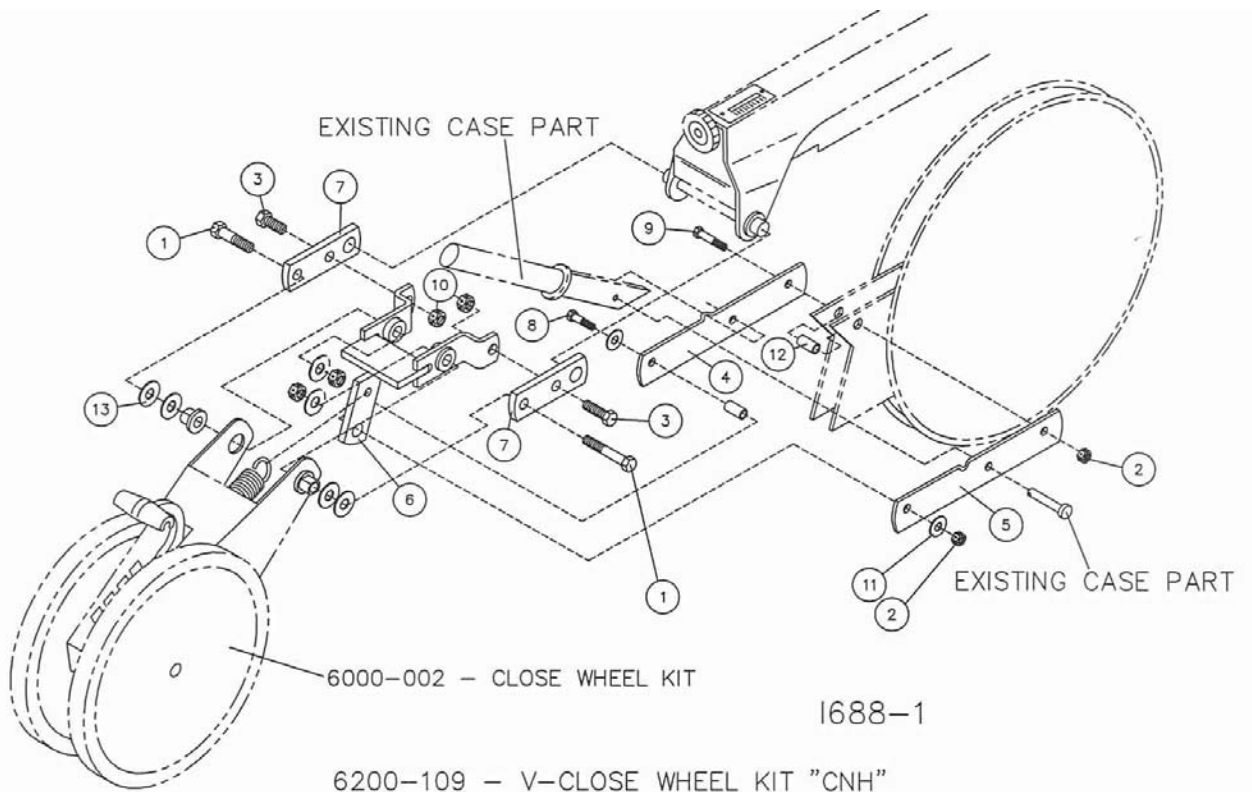

KEY	QTY	PART NO.	DESCRIPTION
1	2	2502-296	1/2-13 X 2 1/2 HHCS GR 5 ZYD
2	2	2520-255	3/8-16 HEX LOCK NUT ZYD
3	2	2502-292	1/2-13 X 1 HHCS GR5 ZP
4	1	6200-306	L.H. SPRING ANCHOR
5	1	6200-305	R.H. SPRING ANCHOR
6	1	6200-202	V-CLOSING WHEEL MNT W.A.
7	2	6200-341	LINK
8	1	2502-232	3/8-16 X 1 1/2 HHCS GR 5 ZYD
9	1	2502-240	3/8-16 X 2 HHCS GR 5 ZYD
10	2	2520-357	1/2-13 LOCK HEX NUT ZP
11	2	2526-253	3/8 SAE FLAT WASHER ZYD
12	2	6200-342	SPACER ZYD
13	4	2526-352	1/2 SAE FLATWASHER ZP

PARTS IDENTIFICATION

6000-002 CLOSE WHEEL KIT ASSEMBLY

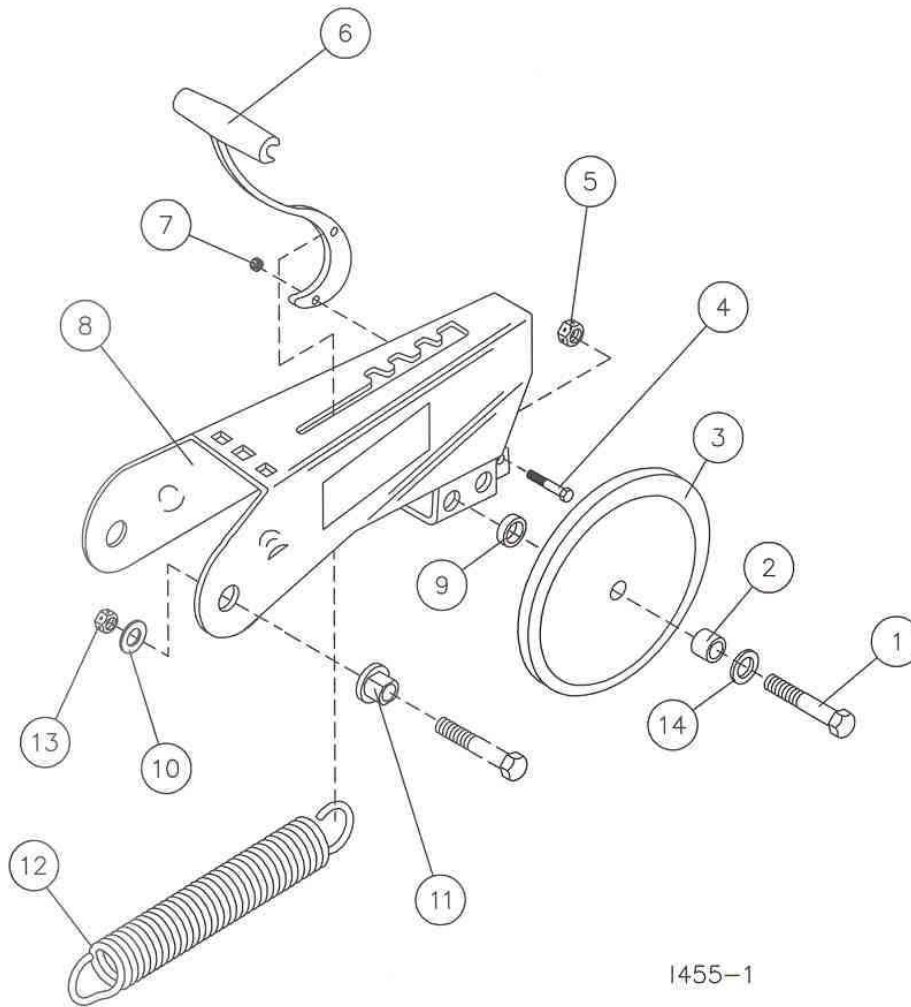

1455-1

KEY	QTY	PART NO.	DESCRIPTION
1	2	2502-336	5/8-11 X 4 HHCS GR. 5 ZP
2	2	6000-335	9/16" BUSHING
3	2	2570-751	1 X 12 NYL CLOSING WHEEL 40MM SMCR
	2	2550-061	BEARING, 40 MM
4	1	2502-206	5/16-18 X 1 1/2 HHCS GR. 5 ZP
5	2	2520-459	5/8-11 LOCK HEX NUT ZP
6	1	6000-524	CLOSE WHEEL LEVER
7	1	2520-205	5/16-18 LOCK HEX NUT ZP
8	1	6000-247	CLOSE WHEEL ARM W.A.
	2	2565-162	YETTER DECAL,1-1/2 X 4-1/2
9	2	6000-336	BUSHING PIVOT
10	2	2526-351	1/2 STANDARD FLATWASHER ZYD
11	2	6000-523	ECCENTRIC BUSHING CLOSE WHEEL
12	1	6000-525	CLOSE WHEEL SPRING (PAINTED)
13	2	2520-357	1/2-13 LOCK HEX NUT ZP.
14	2	2526-453	5/8 SAE FLATWASHER

MAINTENANCE

LUBRICATION

NOTE: For clarity, closing wheel assembly has been removed from row unit.

Oil bushings weekly with general purpose oil.

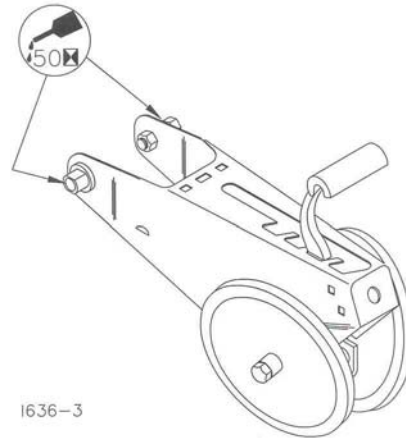

TROUBLESHOOTING

Problem	Possible Cause	Solution
Closing wheel(s) leave severe imprint in soil.	Too much closing wheel down pressure.	Reduce closing wheel pressure.
Closing wheel(s) NOT firming soil around seed.	Insufficient closing wheel pressure.	Increase closing wheel pressure.
Closing wheel running on top of seed trench.	Closing wheels not centered.	Rotate eccentric bushing(s) to center closing wheels.

NOTES

Our name Is getting known

Just a few years ago, Yetter products were sold primarily to the Midwest only. Then we embarked on a program of expansion and moved into the East, the South, the West and now north into Canada. We're even getting orders from as far away as Australia and Africa.

So, when you buy Yetter products . . .you're buying a name that's recognized. A name that's known and respected. A name that's become a part of American agriculture and has become synonymous with quality and satisfaction in the field of conservation tillage.

Thank you.

YETTER MANUFACTURING CO.

Colchester, IL 62326-0358 • 309/776-4111

Toll Free 800/447-5777

Fax 309/776-3222

Website: www.yetterco.com

E-mail: info@yetterco.com